

# NOVALYNX CORPORATION

**MODEL 110-WS-16**  
**MODULAR WEATHER STATION**  
with firmware version 3.0.7 and older

## INSTRUCTION MANUAL

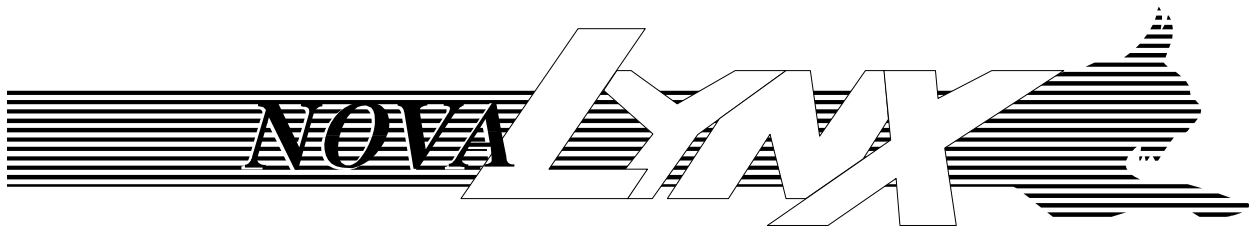

REVISION DATE: NOV 2005

## **Receiving and Unpacking**

Carefully unpack all components and compare to the packing list. Notify NovaLynx Corporation immediately concerning any discrepancy. Inspect equipment to detect any damage that may have occurred during shipment. In the event of damage, any claim for loss must be filed immediately with the carrier by the consignee. Damages to equipment sent via Parcel Post or UPS require the consignee to contact NovaLynx Corporation for instructions.

## **Returns**

If equipment is to be returned to the factory for any reason, call NovaLynx between 8:00 a.m. and 4:00 p.m. Pacific Time to request a Return Authorization Number (RA#). Include with the returned equipment a description of the problem and the name, address, and daytime phone number of the sender. Carefully pack the equipment to prevent damage or additional damage during the return shipment. Call NovaLynx for packing instructions in the case of delicate or sensitive items. If packing facilities are not available take the equipment to the nearest Post Office, UPS, or other freight service and obtain assistance with the packaging. Please write the RA# on the outside of the box.

## **Warranty**

NovaLynx Corporation warrants that its products are free from defects in material and workmanship under normal use and service for a period of one year from the date of shipment from the factory. NovaLynx Corporation's obligations under this warranty are limited to, at NovaLynx's option: (i) replacing; or (ii) repairing; any product determined to be defective. In no case shall NovaLynx Corporation's liability exceed product's original purchase price. This warranty does not apply to any equipment that has been repaired or altered, except by NovaLynx Corporation, or that has been subjected to misuse, negligence, or accident. It is expressly agreed that this warranty will be in lieu of all warranties of fitness and in lieu of the warranty of merchantability.

## **Address**

**NovaLynx Corporation**  
**4055 Grass Valley Highway, Suite 102**  
**Auburn, CA 95602**  
**Phone: (530) 823-7185**  
**Fax: (530) 823-8997**  
**Email: [nova@novalynx.com](mailto:nova@novalynx.com)**  
**Website: [www.novalynx.com](http://www.novalynx.com)**

Copyright © 2000-2005 by NovaLynx Corporation

# TABLE OF CONTENTS

1.0 INTRODUCTION	1
1.1 Data Output, Display, and Logging	1
1.2 Current Observations	1
1.3 Data Logging	2
1.4 Data Acquisition Module	2
1.5 Sensors	2
1.5.1 Wind Speed and Direction	2
1.5.2 Barometric Pressure	3
1.5.3 Temperature and Relative Humidity	3
1.5.4 Rain	3
1.6 Using the Data	3
2.0 INSTALLATION	3
2.1 Installation Considerations	4
2.1.1 Data Acquisition Module	4
2.1.2 Tripod Tower	4
2.1.3 Lightning Protection and Grounding	4
2.2 Power Connections	4
2.2.1 Standard Outlet	4
2.2.2 External Battery Power Option	5
2.2.3 Main Memory Battery Backup	5
2.3 RS232 Interface	5
2.3.1 Testing the Connection	5
2.4 Sensor Installation	6
2.4.1 Data Acquisition Module	7
2.4.2 Wind Speed and Direction Sensor	7
2.4.3 Barometric Pressure Sensor	10
2.4.4 Temperature and Relative Humidity Sensor	10
2.4.5 Rain Gauge	11
3.0 OPERATION	11
3.1 Software	11
3.2 Station Setup	12
3.2.1 Station Name	12
3.2.2 Units of Measure	13
3.2.3 Averaging Period	13
3.2.4 Logging Interval	13
3.2.5 Date & Time	14
3.2.6 Add or Remove Sensors	14
3.3 Power Outage Warning	14
3.4 Current Observations	14
3.5 Weather Trends	15
3.6 Display Log by Hours	16
3.7 Display Log by Days	17
3.8 Data Download	18
3.9 Clear Logging Memory	19
3.10 Alarms	20
3.10.1 Setting up the Alarms	20
3.10.2 Interfacing to the Alarm Circuit	21
3.11 Interfacing the WS-16 with a Telephone Modem	21
4.0 SPECIFICATIONS	22
5.0 ORDERING INFORMATION	23
APPENDIX 1 Sensor Configuration	25

# MODEL 110-WS-16 EQUIPMENT CONFIGURATION AND IDENTIFICATION



110-WS-16 Modular Weather Station  
(Data Acquisition Module shown below)



110-WS-16 Modular Weather Station  
with NEMA-4X Enclosure & Solar Panel



110-WS-16D Data Acquisition Module & 110-WS-16P Power Pack

# NovaLynx Corporation

## Model 110-WS-16 Modular Weather Station Instruction Manual

### 1.0 INTRODUCTION

*Note: This manual is for WS-16 stations with firmware 3.07 and older.*

Congratulations on your purchase of a WS-16 Weather Station and welcome to the world of modular, user-friendly weather data collection. The WS-16 has been carefully designed with the user in mind and we are confident that it will provide you with convenient and accurate weather data for years to come.

The WS-16 is a state-of-the-art, microprocessor-based weather station that provides capabilities unequaled in similarly priced instruments. In its standard configuration, measurements for wind speed, wind direction, air temperature, relative humidity, barometric pressure, and precipitation are collected and processed by the data acquisition module.

Any, or all, of these weather parameters can be included by simply adding the appropriate sensors. The exact configuration is determined by the user, based on demands of the intended application.

Future enhancements will make the WS-16 even more responsive to your needs. The EEPROM in which the operating firmware is stored can be electronically updated to simplify future firmware upgrades.

#### 1.1 Data Output, Display, and Logging

Real-time weather data is output by the WS-16 over its RS232 interface. This text data can be viewed using either a PC-based communications program or an optional display software package purchased with your WS-16 station.

Special consideration has been given in the design of the WS-16's display of current weather data to ensure ease of understanding by the first-time or casual user.

In addition to current weather information, the WS-16's data logging capability allows up to 45 days of data taken at 15 minute intervals to be stored in memory for later retrieval.

#### 1.2 Current Observations

This display is a one-page report of current weather conditions, with each parameter clearly labeled on the screen. (See Figure 4, Page 9.)

In addition to the measured parameters, the WS-16 calculates values for wind chill and dew point. The WS-16 also reports specific aspects of the measured parameters including peak wind speed, wind direction variation, hourly temperature change,

maximum and minimum daily temperature, barometric pressure change, maximum and minimum daily pressure, relative humidity change, and daily and monthly precipitation accumulation.

### **1.3 Data Logging**

The time interval between recordings is user determined for periods ranging from one minute to sixty minutes. This logged data can be retrieved for viewing or permanent storage using the options available on the main menu.

When retrieved for viewing, the logged data is displayed as date and time stamped, single line, row and column entries. Logged data can be retrieved in either hourly or daily blocks.

For permanent storage, the data logged by the WS-16 can be copied to a computer hard drive or external media. The comma delimited format of the logged data has been designed to be compatible with most commercial spreadsheet software (Excel, Lotus 1-2-3, OpenOffice.org, and Quattro Pro, among others).

### **1.4 Data Acquisition Module**

The heart of the WS-16 is the data acquisition module. It conditions and processes the signals generated by the attached sensors and outputs them via the RS232 interface at a default rate of 9600 bits per second. Other bit rates are user selectable.

In addition to the RS232 interface connector, the data acquisition module provides connections for all of the weather sensors.

Power is provided by an external 12Vdc source and the WS-16 comes equipped with a 12Vdc wall transformer for powering the station from a standard 110Vac outlet. (An optional 220vac transformer is available.) A 12Vdc battery can be used to provide emergency power in the event of a loss of main power. See section 2.2.

### **1.5 Sensors**

The standard WS-16 sensors have been designed to be rugged, compact, and lightweight. They interface directly to the data acquisition module without the need for additional signal conditioning.

#### **1.5.1 Wind Speed and Direction**

The wind sensor combines a three-cup anemometer and a wind vane on a single axis. The anemometer is a contact-type wind sensor which, when rotated by the wind, triggers a series of momentary switch closures that are directly related to wind speed.

The wind vane uses a potentiometer to sense direction changes. Depending on the position of the potentiometer wiper, an analog voltage is output that corresponds to the position of the vane. By orienting the vane to North (360 degrees) during installation,

wind can be easily calculated from the output voltage. The resolution of the wind vane is 1 degree (azimuth display), or 16 compass points (cardinal points display).

### **1.5.2 Barometric Pressure**

Barometric pressure is sensed using a piezoresistive sensing element. This element responds to changes in barometric pressure with a corresponding change in resistance. This resistance is converted to a voltage from which the microprocessor calculates the barometric pressure at the elevation where the sensor is located.

The barometric pressure sensor is set for sea level when it leaves the factory. Because pressure varies with elevation, the sensor must be adjusted to read correctly for the elevation at which it is installed. This is done using the offset adjustment screw located on the side of the sensor. Instructions are provided in the installation section of this manual. (See page 10.)

### **1.5.3 Temperature and Relative Humidity**

The WS-16 is designed to accommodate a combination temperature and relative humidity sensor. Temperature is sensed using a thermistor element which changes resistance in response to temperature fluctuations. Relative humidity is sensed by changes in the dielectric constant of a thin polymer film as it absorbs moisture or sheds it to the surrounding air.

For maximum accuracy, the sensor should be isolated from the effects of sunlight which can cause misleading temperature and humidity measurements. The WS-16-THS self-aspirated solar radiation shield is provided to give this protection.

### **1.5.4 Rain**

The rain gauge provided with the WS-16 is a traditional tipping bucket design. Resolution is 0.01 inches (0.254 mm) per tip.

## **1.6 Using the Data**

Once the weather data generated by the WS-16 has been logged and saved, either within the data acquisition module or on external media, it can easily be manipulated by a number of commercially available software packages. The format of the columnar, coma-delimited data was carefully designed to make it compatible with most widely used spreadsheet programs. The data can be imported easily into these programs and then analyzed or manipulated, making the information generated by the WS-16 much more than simply a collection of numbers.

## **2.0 INSTALLATION**

Installation of the WS-16 is simple and straightforward, thanks to its modular design and terminal-strip connections.

## 2.1 Installation Considerations

Prior to installing the WS-16, you should be aware of several important points that must be taken into consideration when choosing a site for the data acquisition module and sensors.

### 2.1.1 Data Acquisition Module

The data acquisition module should be located as close as possible to the computer that will be used to communicate with the WS-16. RS232 communications (the communication protocol used by the WS-16) is designed for use over short distances, and the cable connecting the module to the computer should not be longer than 200 feet (60 meters), although longer lengths may work. If this arrangement is not feasible, an RS232 to RS422 converter can be added to allow longer cable runs.

### 2.1.2 Tripod Tower

The five-foot tripod tower provided with the WS-16 is constructed of steel tubing for durability and strength. Horizontal bracing is a feature of the tripod tower. The tripod's foot brackets can be bolted onto a concrete foundation or a wooden platform. The wind speed and direction sensor mounts on top (the tapered end) of the five-foot aluminum sensor mast. The solar radiation shield (for the temperature and humidity sensor) and the rain gauge mounting arm are supplied with u-bolts to clamp onto this mast. For stability, we recommend that the mast be inserted into both of the tripod's collar clamps. Guy kits are recommended for areas of high winds and ground kits are recommended for areas with lightning activity.

**Caution:** When installing the wind sensor, make sure that the sensor and cable are well clear of any power lines.

### 2.1.3 Lightning Protection and Grounding

A brass lightning protection ground screw, located on the data acquisition module, is the path to ground for all of the lightning protection circuitry in the WS-16. Connect this screw to a grounded outlet or water pipe. In areas subject to severe lightning activity, we recommend that you install a grounding rod.

## 2.2 Power Connections

The WS-16 can be operated from a standard 110Vac outlet, a standard 220Vac outlet, or from an external 12Vdc battery.

### 2.2.1 Standard Outlet

A wall transformer is provided with the unit for operating from a standard 110Vac outlet. An optional wall transformer is available for operating from a 220Vac/50Hz power source. The wall transformer provides a nominal 12Vdc.



## 2.2.2 External Battery Power Option

The optional 110-WS-16PBU Battery Backup for the WS-16D consists of a 12V battery and a float-type battery charger. The battery is used as the main power source, with the float charger continuously keeping it at full charge. A fully-charged 12V 7AH battery will run the WS-16 for three to four days, allowing the station to continue collecting and logging data during a power outage. When power is restored, the charger will automatically recharge the battery.

## 2.2.3 Main Memory Battery Backup

The WS-16's main memory has a lithium battery backup so that setup parameters, as well as any stored data, will be retained even if the primary power source is interrupted.

## 2.3 RS232 Interface

The WS-16 is an interactive device that not only outputs data but is capable of responding to user commands. These commands are entered through the computer, which also displays the current data and any additional data requested by the user. Communication between the user and the WS-16 is accomplished using RS232 communications protocol designed for short-distance use.

The standard 6-foot serial interface cable that connects the data acquisition module to the computer is terminated with a 9-pin "D" connector. A 25-pin to 9-pin adapter may be used, if required. The serial cable can be extended up to 200 feet, or more.

For computers without a serial port, a USB-to-Serial converter may be used. When installing the converter, be sure to note the Com port number it is assigned.

Connect the serial interface cable between the data acquisition module and the computer's serial port (usually Com 1 or Com 2) or USB-to-Serial converter.

Certain communications parameters must be specified in the computer to enable the two devices to communicate. Using a communications software program such as HyperTerminal or ProComm, set them as follows:

Bits per second	9600
Data bits	8
Parity	None
Stop bits	1
Flow control	None
Emulation	ANSI

### 2.3.1 Testing the Connection

Once the WS-16 is connected to the computer, the connection can be tested by turning the "on/off" switch on the data acquisition module to the off position for several seconds and then on again.

If the RS232 connection is sound, the NovaLynx Corporation header and the software version will appear on the screen.

```
WeatherPort WS-16
Modular Weather Station

NovaLynx Corporation Inc.
Version: 3.0.7 (c)1996-2004 Mesotech
Protected by USA and Int'l copyright laws

Press M key, followed by Enter for main menu
```

Figure 1

If nothing appears on the screen, unplug the serial cable from the WS-16 module and plug in the WS-16 RS232 Output Tester supplied with the unit. If the module is functioning, the red light should flash every 5 seconds.

If the module is functioning but you still see nothing on the screen, the wrong serial port may be selected. Try selecting Com 2 or another functioning serial port. You can see a list of available ports in My Computer > System Properties > Device Manager > Ports.

## 2.4 Sensor Installation

Install the sensors in their chosen locations, bearing in mind the installation considerations noted earlier. Run cables from the sensors to the data acquisition module location, with no cable exceeding the maximum allowable length listed below.

Sensor	Maximum Cable Length
Wind*	250' (76m)
T/RH*	250' (76m)
Rain*	900' (275m)
Barometric Pressure**	10' (3m)
Solar Radiation*	100' (33m)
*Std cable length 40' **Std cable length 18"	

When the sensors have been installed and the cables run, connect and test them as described in the following sections. Refer to the hook-up drawing at the back of this manual to verify wire colors and physical connections.

## 2.4.1 Data Acquisition Module

The data acquisition module is configured at the factory for the following sensors:

1. Wind speed and direction
2. Barometric pressure
3. Temperature and relative humidity
4. Rain gauge

To verify the sensor setup, press "M" and "Enter" to go to the main menu. Select item "1", Station setup. From the setup menu select "6", Add or remove sensors. Press "Y" to continue. The sensor configuration screen will appear showing all of the presently enabled sensors. Refer to Appendix 1 for instructions, should any sensor that you plan to use not be enabled.

```
WeatherPort WS-16
Modular Weather Station

Setup Menu

1. Station name: Weather Station
2. Units of measure: English
3. Averaging period: 15 minutes
4. Logging interval: 15 minutes
5. Date & Time: 10/12/2005 08:27
6. Add or remove sensors
7. Enter alarm thresholds
8. Communications settings
9. Return to main menu

Enter your selection [1 - 9]:6

WeatherPort WS-16
Modular Weather Station

Sensor Configuration

Sensor Type      Model      Input      Calibration
-----
1. Wind Speed    200-WS-01/02    P1
2. Precipitation All models     P3      0.0100
3. Pressure      100-WS-16BP    A2
4. Humidity      110-WS-16TH    A4
5. Temperature   225-501/110-WS-16TH A5
6. Wind Direction 200-WS-02/05    A7

Add sensor [A], delete sensor [D], or quit [Q]:_
```

Figure 2: Station Setup Menu & Sensor Configuration Menu

## 2.4.2 Wind Speed and Direction Sensor

Connect the wind sensor cable to the terminal strip on the data acquisition module. This sensor has a four conductor shielded cable. The RED wire is connected to the +5 REF

terminal; The BLACK wire is connected to a GROUND terminal; the GREEN wire (wind direction signal) is connected to the A7 terminal and the WHITE wire (wind speed signal) is connected to the P1 terminal.

The wind vane requires alignment of the “dead band” or potentiometer gap to North, either magnetic or true North, to obtain valid measurements. Alignment can be done at ground level allowing easier installation of the sensor, but it must be checked again after the sensor has been fully installed.

The wind sensor base is used to orient the wind vane to North. Normally, wind direction sensors are aligned to true North, rather than magnetic North. True North can be found by reading a magnetic compass and applying the correction for magnetic declination, where magnetic declination is the number of degrees between true North and magnetic North.

Alignment involves creating an imaginary line running through the wind sensor from North to South. When this line has been established, the mounting base of the sensor is rotated until the screw head in the base and the screw hole that is just above it in the sensor body both point toward North. Rotate the sensor housing until the two screw holes point toward the North.

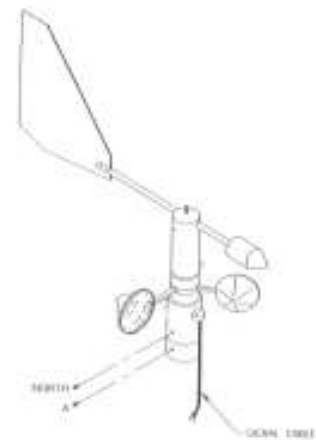

Call up the main menu (Figure 3, Page 9) on the display terminal by pressing "M" and "Enter". Press "2" for current observations. Then press "1" for observation display (Figure 4, Page 9).

Turn the anemometer cups by hand, wait for the screen to update, every five seconds, and note the wind speed displayed on the screen. (It will read about 7 to 12 mph.) This value should change as you spin the cups.

Rotate the vane tail until the counter-weight nose also points to North and is in line with the two screw holes. Check the output signal of the direction sensor. If the alignment is correct, the output signal should indicate North (0 or 360 degrees). Correct the sensor base rotation to bring the reading into agreement with the compass. When the alignment appears to be good, secure the sensor base set screws to the mast. Turn the vane in increments around the full 360 degrees, noting the change in the wind direction readings. These should agree with the position of the vane.

Wind coming from:	Equals:
North	0°
East	90°
South	180°
West	270°

```
WeatherPort WS-16
Modular Weather Station
```

```
Main Menu
```

1. Station setup
2. Current observations
3. Display log by hours
4. Display log by days
5. Data download
6. Clear logging memory

```
Enter your selection [1 - 6]:2
```

```
WeatherPort WS-16
Modular Weather Station
```

```
Display Format Menu
```

1. Observation display
2. Row and column display
3. Return to main menu

```
Enter your selection [1 - 3]:1
```

**Figure 3: Main Menu & Display Format Menu**

```
Station: Weather Station                                10/12/2005 08:42:45
=====
WIND SPEED:  1.8mph, peak windspeed 2.0mph during past 10 min.
DIRECTION:   ESE, 115deg, varying 76deg during past 10 min.
WINDCHILL:   +76F

CURRENT TEMPERATURE: +75.8F, +0.5F change during past hour
TODAY'S HIGH/LOW:    +76F at 08:42, +75F at 08:32
DEW POINT:          +29F
AUX TEMPERATURE:    +0.0F, +0.0F change during past hour

SOLAR RADIATION:     0W/m^2

BAROMETER:          28.33in, +0.00in change during past 3 hours
TODAY'S HIGH/LOW:    28.34in at 08:32, +28.33in at 08:40

RELATIVE HUMIDITY:   17%, +0% change during past hour

PRECIPITATION:       Precipitation detected
                     Since Last Log:  0.06in
                     Today:            0.52in
                     This Month:       1.06in

(Press M key followed by Enter key for main menu)
```

**Figure 4: Current Observations Display**

### **2.4.3 Barometric Pressure Sensor**

The barometric pressure sensor is designed to be mounted indoors. This arrangement assumes that the barometric pressure indoors and outdoors is equal. The barometric pressure sensor is provided with a short cable that connects directly to the data acquisition module.

Connect the barometric pressure sensor cable to the terminal strip on the data acquisition module. This sensor has a three conductor cable. The RED wire is connected to a +12V terminal. The BLACK wire is connected to a GROUND terminal and the GREEN wire is connected to terminal A2.

The barometric pressure sensor is set for sea level when it leaves the factory and will show absolute pressure readings at elevations below 1,200 feet. Because pressure varies with elevation, the sensor must be adjusted to read correctly for the elevation at which it is installed.

The barometric pressure range is 28.25 to 30.75 inches of mercury. Nominal barometric pressure is 29.6 inches of mercury. If the reading is 28.25 or 30.75, the sensor must be adjusted. This is done using the offset adjustment screw located on the side of the sensor.

Before setting the barometric pressure offset for sea level, you must first obtain a reliable barometric pressure for your location. This can be found by contacting the nearest airport or weather service facility.

Call up the main menu (Figure 3, Page 9) on the display terminal by pressing "M" and "Enter". Press "2" for current observations. Then press "1" for observation display (Figure 4, Page 9).

While watching the display screen, slowly turn the offset adjustment screw. Turning clockwise will decrease the pressure reading. You may have to turn the adjustment screw 3 to 10 revolutions before the display starts to change. Turn the pot slowly in single turn increments, then wait for the screen to update, every five seconds. If the value is moving away from the correct value obtained above, turn the screw in the opposite direction. Continue turning the screw until the displayed value agrees with the value obtained from the airport or weather service.

### **2.4.4 Temperature and Relative Humidity Sensor**

Connect the combination temperature and relative humidity sensor cable to the terminal strip on the data acquisition module. This sensor has a five conductor cable. The RED wire is connected to the +12 REF terminal. The BLACK wire is connected to a GROUND terminal. The BROWN wire (humidity signal) is connected to the A4 terminal. The WHITE (temperature signal) is connected to the A5 terminal and the GREEN wire is connected to a GROUND terminal.

Call up the main menu (Figure 3, Page 9) on the display terminal by pressing "M" and "Enter." Press "2" for current observations. Then press "1" for observation display (Figure 4, Page 9).

Obtain current values for temperature and humidity from the nearest airport or weather service facility, and see that the values shown on the main display agree approximately with them.

To simulate a change in temperature and humidity, lean close to the sensor (or to the solar shield) and breathe onto the sensor until you see a corresponding change in the displayed temperature and humidity values.

### **2.4.5 Rain Gauge**

Connect the rain gauge cable to the terminal strip on the data acquisition module. This sensor has a two conductor cable. Connect one conductor to a GROUND terminal and the other conductor to terminal P3.

While watching the observation display, manually tip the bucket or add a tablespoon or two of water into the funnel until the bucket tips. If the rainfall amount displayed on the screen increases by the expected increment (usually 0.01" or 0.254 mm) each time you tip the bucket, your rain gauge is working properly.

## **3.0 OPERATION**

The WS-16 Weather Station collects and logs data automatically, requiring little user input. Ultimate control, however, is provided by the interactive user interface, which allows the user to direct the WS-16 to perform certain specific functions by choosing one of the six options offered on the main menu (Figure 3, Page 9).

### **3.1 Software**

The firmware in the WS-16 contains all of the programs required to use the weather station with a PC operating in communications mode (such as HyperTerminal in Windows). The WS-16 and the PC communicate through the RS232 serial interface cable installed between the data acquisition module and a serial port of the computer (usually Com 1 or Com 2). To help you get started if you are using Windows 98/2000/XP, we have provided a quick start disk that automatically opens the HyperTerminal program with all the proper settings for communicating with the WS-16 using Com 1 or Com 2.

The communications parameters required to interface the WS-16 to an RS232 data link are as follows:

Bits per second	9600
Data bits	8
Parity	None
Stop bits	1
Flow control	None
Emulation	ANSI

Once the main menu is present, proceed with the station setup procedures as described in the next section.

### 3.2 Station Setup

Call up the main menu by pressing "M" and "Enter". Press "1" to initiate the station setup procedure. This procedure allows you to specify certain operational parameters that the WS-16 uses in its calculations and on its display. Run station setup when using the weather station for the first time. After that, ignore it—unless you wish to change one or more of the settings.

When you press "1" at the main menu, the parameters available for customizing appear as items 1 through 9.

```
Setup Menu

1. Station name: Weather Station
2. Units of measure: English
3. Averaging period: 15 minutes
4. Logging interval: 15 minutes
5. Date & Time: 10/12/2005 08:27
6. Add or remove sensors
7. Enter alarm thresholds
8. Communications settings
9. Return to main menu

Enter your selection [1 - 9]:_
```

Figure 5: Station Setup Menu

#### 3.2.1 Station Name

Press "1", Station name. Type the name of the station. The station name may be any series of alphanumeric characters up to 50 characters long. After the station name is entered press "Enter" and select the next item.



### 3.2.2 Units of Measure

Press "2", Units of measure. A warning message will appear stating, Changing units will cause data to be logged in the new units of measure. You should clear logging memory to avoid mixed data values. Do you want to continue? [Y or N]: If you want to change units of measure press "Y" and the menu will ask you English or Metric? Select "E" or "M" and press "Enter".

The menu will ask if you are sure you want to delete log file [Y or N]. If you have changed units then answer "Y" if not "N" and press "Enter".

Parameter	English	Metric
Wind Speed	mph	m/s
Wind Direction	degrees	degrees
Temperature	°F	°C
Humidity	%	%
Barometric Pressure	inHg	mb
Precipitation	inches	mm

### 3.2.3 Averaging Period

Press "3", Averaging period. The averaging period is user selectable over the range from 1 minute to 60 minutes. The stored data will be the average of the data measured at five-second intervals over the user selected averaging period. If the averaging period is less than the logging interval, the average logged will be for a period of time at the end of the logging interval equal to the averaging period. If the averaging period is longer than the logging interval then the data stored will be a running average that reaches back into previous logging intervals. The averaging period is usually set to 15 minutes or the same as the logging interval.

Enter the number of minutes desired and press "Enter".

### 3.2.4 Logging Interval

Press "4", Logging interval. The menu will ask you to enter a number between 1 and 60 minutes. The logging interval is usually set to 15 minutes. Enter your selection and press "Enter".

The number of days of data that can be stored in the memory is a function of the logging interval, the magnitude of the data reported, and the number of sensors activated. With the standard complement of sensors (wind speed, wind direction, temperature, relative humidity, barometric pressure, and precipitation) the memory will fill in about 45 days if the logging interval is 15 minutes. Once the memory is full it "wraps," that is it continuously over-writes the oldest data in the memory with new data.

### **3.2.5 Date & Time**

Press "5", Date & Time. The menu will direct you to enter the current date in the following format: [MM/DD/YYYY]. When the proper date has been entered press "Enter". The menu will direct you to enter the current time in 24 hour format [HH:MM]. When the proper time has been entered press "Enter".

### **3.2.6 Add or Remove Sensors**

Press "6", Add or remove sensors. The menu displays the following warning, You must off-load data before changing sensor configuration. Logging memory will be automatically cleared if changes are made. Do you want to continue? [Y or N]: Press "Y" and the sensor configuration screen will appear. If all of the sensors that you intend to use are shown as being configured, press "Q" and "Enter". If you wish to add or delete a sensor, press "A" for add or "D" for delete and follow the instructions presented on the menu.

### **3.3 Power Outage Warning**

The data entered using the station setup procedure is automatically stored in the system's memory. The data will remain intact even if there is a power outage. All data collected will also remain intact if there is a power outage. However, the system will not report or log data during periods of power outage. When reviewing data logs, gaps in the store data may be attributed to power outages.

### **3.4 Current Observations**

Press "2" at the main menu to access the most frequently used screens. These are the current observations screens, and they are shown in Figure 4 on page 9 (Observation Screen) and Figure 6 on page 15 (Row and Column Display Screen). The current observations screens show the values currently being measured by the station's sensors. These values are updated every five seconds and provide a running record of weather conditions. The topmost line on the line on the main text display screen shows the station name, current date, and time.

Note: If at any time you get no response when pressing "M" and "Enter" to get the main menu, you can turn the WS-16 module off and then back on to "reboot" the station. No data will be lost.

WeatherPort WS-16  
Modular Weather Station

Display Format Menu

1. Observation display
2. Row and column display
3. Return to main menu

Enter your selection [1 - 3]:2

Please wait 5 seconds for next display

10/12/2005, 09:12:05,	2.00,	0.00,	28.33,	17.14,	77.35,	341.89,	77.35,	30.02
10/12/2005, 09:12:10,	1.50,	0.00,	28.33,	17.12,	77.38,	321.89,	77.38,	30.01
10/12/2005, 09:12:15,	1.25,	0.00,	28.33,	17.12,	77.45,	346.89,	77.45,	30.07
10/12/2005, 09:12:20,	1.00,	0.00,	28.33,	17.12,	77.42,	331.81,	77.42,	30.04
10/12/2005, 09:12:25,	3.75,	0.00,	28.33,	17.12,	77.48,	341.98,	77.48,	30.09
10/12/2005, 09:12:30,	1.50,	0.01,	28.33,	17.12,	77.48,	311.89,	77.48,	30.09
10/12/2005, 09:12:35,	1.75,	0.00,	28.33,	17.14,	77.42,	321.81,	77.42,	30.08
10/12/2005, 09:12:40,	1.25,	0.00,	28.34,	15.78,	85.48,	332.81,	85.48,	34.70
10/12/2005, 09:12:45,	1.00,	0.00,	28.34,	16.20,	82.58,	341.89,	82.58,	32.96

(Press M key followed by Enter key for main menu)

Wind Speed / Rain / Baro Pressure / Temperature / Humidity / Wind Dir / Wind Chill / Dew Point  
(Note: These labels do not appear on screen)

Figure 6: Row and Column Presentation of Current Observations

### 3.5 Weather Trends

The current observations text screen displays several weather features in addition to the current sensor readings. These values show the extent to which the measured parameters have varied over an extended period:

- The peak wind speed, with the highest value recorded during the past 10 minutes displayed
- The high and low temperatures for the day (based on measurements taken since 12 midnight) and the change in temperature in the past hour.
- The high and low barometric pressure for the day (based on measurements taken since 12 midnight) and the change in barometric pressure over the past three hours.
- The change in relative humidity over the past hour.
- Three values for precipitation accumulation, with totals for the past logging interval, for the current day (rainfall since 12 midnight), and for the current month (rainfall since the first of the month, according to the date set through the station setup procedure).

**Caution:** If power is interrupted, the stored trend values will be cleared and reset to the current date and time. All three precipitation totals will go to 00.00 and today's hi/low will be the current temperature.

### 3.6 Display Log by Hours

Press "3" at the main menu to view the WS-16's stored data and to specify the amount of data to be retrieved in hours. (If you wish to view a full day of data, or more, choose selection "4" Display Log by Days.)

After selecting "3" from the main menu, specify the number of hours of data to be retrieved.

The data will be displayed in the format shown in Figure 7 on page 17. The data is organized into columns, with an abbreviation for each parameter and the units of measure used (selected through the setup menu) shown at the top of the column.

- DATE - Date the data was logged. This date is based on the date selected in the station setup procedure.
- TIME - Time the data was logged in military time (24-hour clock). This time is based on the time selected in the station setup procedure.
- WS - Wind speed in miles per hour or meters per second.
- PK - Peak wind speed in miles per hour or meters per second. This is the highest wind speed measured over any two second interval.
- WD - Wind direction in degrees.
- T1 - Temperature measured by the temperature and relative humidity probe in degrees Fahrenheit or degrees Celsius.
- T2 - Temperature measured by an auxiliary temperature probe (if used) in degrees Fahrenheit or degrees Celsius.
- RH - Relative humidity measured by the temperature and relative humidity probe in percent.
- BP - Barometric pressure in inches of mercury or millibars. This is the average pressure measured during the logging interval.
- RF - Precipitation (rainfall) accumulated during the logging interval in inches or millimeters.
- SR - Solar radiation in watts per square meter.

A maximum of 18 records can be displayed on a single screen, so if more than 18 hours were requested the data will be continued on subsequent screens.

To view the next screen, simply press the space bar. Each successive screen may be viewed by pressing the space bar. You may not, however, return to a previous screen. You must return to the main menu and begin the retrieval procedure again.

If you want to further manipulate the data, or obtain a printed copy, follow the procedure described in the data download section on page 18.

Enter number of hours to view: 1

DATE	TIME	WS	PK	WD	T1	T2	RH	BP	RF	SR
M/D	H:M	mph	mph	deg	F	F	%	inHg	in	W/m^2
10/12	07:10	0.6	2.8	50	+72.9	+0.0	18	28.33	0.00	0
10/12	07:15	1.0	2.8	58	+73.0	+0.0	18	28.33	0.00	0
10/12	07:20	0.8	2.8	53	+73.1	+0.0	18	28.33	0.00	0
10/12	07:25	2.4	4.2	58	+73.1	+0.0	18	28.33	0.00	0
10/12	07:30	1.5	3.5	60	+73.1	+0.0	18	28.33	0.00	0
10/12	07:35	0.6	2.8	62	+73.2	+0.0	18	28.33	0.00	0
10/12	07:40	0.9	2.8	299	+73.2	+0.0	18	28.33	0.00	0
10/12	07:45	0.2	2.2	326	+73.2	+0.0	18	28.33	0.00	0
10/12	07:50	0.6	2.2	347	+73.6	+0.0	18	28.33	0.00	0
10/12	07:55	0.4	2.8	11	+74.2	+0.0	18	28.33	0.00	0
10/12	08:00	0.6	2.8	58	+74.6	+0.0	18	28.33	0.00	0
10/12	08:05	0.4	2.8	99	+75.4	+0.0	17	28.33	0.00	0
10/12	08:10	1.5	4.0	21	+75.2	+0.0	18	28.33	0.00	0
10/12	08:15	0.6	2.5	357	+74.9	+0.0	18	28.33	0.00	0
10/12	08:20	1.1	3.2	5	+74.7	+0.0	18	28.33	0.00	0
10/12	08:35	0.2	1.0	137	+75.1	+0.0	18	28.33	0.00	0
10/12	08:40	0.2	1.8	123	+75.2	+0.0	18	28.33	0.00	0
10/12	08:45	0.8	3.2	74	+75.7	+0.0	17	28.33	0.06	0

Press Enter to continue or another key to exit: \_

Enter number of hours to view: 1

DATE	TIME	P1	PP1	P3	A2	A4	A5	A7
10/12	07:10	0.62	2.75	0.00	28.33	17.88	72.94	50.19
10/12	07:15	1.00	2.75	0.00	28.33	17.88	73.00	58.19
10/12	07:20	0.75	2.75	0.00	28.33	17.88	73.06	53.00
10/12	07:25	2.44	4.25	0.00	28.33	17.88	73.06	58.44
10/12	07:30	1.50	3.50	0.00	28.33	17.88	73.12	59.75
10/12	07:35	0.62	2.75	0.00	28.33	17.81	73.19	62.19
10/12	07:40	0.94	2.75	0.00	28.33	17.81	73.19	298.56
10/12	07:45	0.25	2.25	0.00	28.33	17.81	73.19	325.81
10/12	07:50	0.62	2.25	0.00	28.33	17.75	73.62	347.44
10/12	07:55	0.38	2.75	0.00	28.33	17.69	74.19	11.06
10/12	08:00	0.56	2.75	0.00	28.33	17.56	74.62	58.19
10/12	08:05	0.44	2.75	0.00	28.33	17.44	75.38	98.81
10/12	08:10	1.50	4.00	0.00	28.33	17.50	75.25	21.38
10/12	08:15	0.62	2.50	0.00	28.33	17.50	74.94	357.19
10/12	08:20	1.12	3.25	0.00	28.33	17.56	74.69	4.56
10/12	08:35	0.19	1.00	0.00	28.33	17.50	75.12	137.31
10/12	08:40	0.25	1.75	0.00	28.33	17.50	75.19	123.44
10/12	08:45	0.81	3.25	0.06	28.33	17.38	75.69	73.56

Press Enter to continue or another key to exit: \_

Figure 7: Logged Data Displays, Observation Mode (top), Row and Column Mode (bottom)

### 3.7 Display Log by Days

This procedure is identical to the “Display Log by Hours” option with the exception that data is retrieved in multiples of one day.

This displayed data is in the same format as the logged data retrieved by hours. See Figure 7 on page 17 and the preceding section "Display Log by Hours" for a detailed explanation of the data format.

To display logged data sorted by days:

Press "4" at the main menu. Enter the number of days to be retrieved (any number from 1 to 100).

A maximum of 18 records can be displayed on a single screen, so if more than 18 days were requested the data will be continued on subsequent screens.

To view the next screen, simply press the space bar. Each successive screen may be viewed by pressing the space bar. You may not, however, return to a previous screen. You must return to the main menu and begin the retrieval procedure anew.

If you want to further manipulate the data, or obtain a printed copy, follow the procedure described in the data download section below.

### **3.8 Data Download**

Selection 5 on the main menu allows you to save a permanent record of the WS-16's stored data. The data retrieval procedure is dependent on the communications software program used. Using Microsoft's HyperTerminal software, saving the data to disk is accomplished as follows:

- Press "5" at the main menu.
- Then press "Y".
- At the top of the HyperTerminal screen, click on "Transfer".
- Click on "Receive File"; make sure the protocol is XMODEM; enter the directory and folder name where you want to store the data.
- Click on "Receive" and enter the file name (e.g. weather01.txt).
- Click on "OK". The download will start and a new window will pop-up.
- Press "Enter" when complete. The pop-up window will close.

Transfer time from a full memory may take up to eleven minutes due to the error checking and the de-convolution of the binary data to ASCII format. The downloaded file can be imported into a spreadsheet or word processing program for viewing or manipulating.

The format of downloaded data is shown in Figure 8 on page 19.

The total contents of the memory is downloaded each time the memory download procedure is invoked. The data transfer is a nondestructive readout. The data will remain in memory after downloading. See Section 3.9 if you wish to clear the logging memory.

Main Menu

1. Station setup
2. Current observations
3. Display log by hours
4. Display log by days
5. Data download
6. Clear logging memory

Enter your selection [1 - 6]: 5

Press the Y key when ready for  
Xmodem file transfer, or press  
any key to return to the main menu. Y

Off loading data by Xmodem protocol.

TYPICAL SAMPLE DATA (WITH 6 SENSORS) SAVED AND VIEWED WITH NOTEPAD

```
"Weather Station"  
"DATE", "TIME", "WS", "PK", "RF", "BP", "RH", "TP", "WD"  
10/07,09:20,2.94,3.75,0.00,28.33,17.19,77.00,334.19  
10/07,09:25,1.50,4.00,0.00,28.33,17.12,77.38,341.06  
10/07,09:30,0.25,2.00,0.00,28.33,17.06,77.75,339.12  
10/07,09:35,1.12,3.00,0.00,28.33,17.00,78.12,308.44  
10/07,09:40,1.19,4.25,0.00,28.33,16.88,78.62,103.69  
10/07,09:45,1.25,3.75,0.00,28.33,16.81,79.06,125.56  
10/07,09:50,1.06,3.00,0.00,28.33,16.75,79.44,163.06  
10/07,09:55,1.00,2.75,0.00,28.33,16.69,79.69,123.06  
10/07,10:00,1.62,4.00,0.00,28.33,16.69,79.88,228.94  
10/07,10:05,1.44,4.25,0.00,28.33,16.62,80.06,240.69  
10/07,10:10,1.19,4.50,0.00,28.33,16.62,80.12,86.00  
10/07,10:15,1.44,4.00,0.00,28.33,16.56,80.25,131.88  
10/07,10:20,2.06,4.50,0.00,28.33,16.56,80.38,148.94
```

Figure 8: Data Download (with 5 minute logging interval)

### 3.9 Clear Logging Memory

The final selection on the main menu lets you erase the stored data from the WS-16's memory and begin logging fresh data.

Once the WS-16's available memory is filled with data, incoming records will replace the oldest stored data, and that data will be erased. The clear logging memory option allows you to clear the entire memory.

**Remember:** Once the memory is cleared, the data cannot be retrieved (unless it has been copied to a disk using the data download option).

To clear the logging memory:

At the main menu press "6", Clear logging memory. The following message appears:  
Are you sure you want to delete log file [Y or N]:

If you want to continue, press "Y".

The following message will appear: Erasing Data Memory. Please wait.

When the memory is erased, the WS-16 returns to the current observations screen and data logging resumes. (This takes about 10 to 30 seconds.)

### **3.10 Alarms**

There are six user programmable alarms on the WS-16. They can be assigned to either of two alarm switches (Alarm 1 and Alarm 2) which provide a switched connection to ground. Electrical connection is made to the terminal strip at the positions labeled Alarm 1 and Alarm 2. The maximum current sinking capability of these switches is 2 amps.

#### **3.10.1 Setting up the Alarms**

To select the sensor to be alarmed, the alarm thresholds, and the on and off delays for each alarm:

Press "Enter" to get to the main menu.

From the main menu press "1", Station setup

From the station setup menu press "7", Enter alarm thresholds.

Select Add, Delete, or Quit. If you select Add, the next menu will display the list of sensors that are currently activated.

To add an alarm, enter the sensor number.

Enter the type of alarm function you wish to use: Exclusive (alarm switch is closed when the reported sensor value is outside of the low and high values selected) or Inclusive (alarm switch is closed when the reported sensor value is between the low and high values selected).

Enter output: A1 [1] or A2 [2].

Enter low threshold.

Enter high threshold.

Enter on delay in seconds [0-1200]. This is the time that the sensor value is in the alarm condition before the alarm switch activates.

Enter off delay in seconds [0-1200]. This is the time that the alarm switch drops out of the alarm condition before the alarm switch deactivates.

After entering this information the setup menu reappears. To add additional alarms the process must be repeated.



### **3.10.2 Interfacing to the Alarm Circuit**

Use only 12Vdc powered lights or buzzers, low current < 200 mA maximum, observe polarity. An intermediate relay is recommended as the alarm interface to the device being controlled by the alarm. The intermediate relay provides isolation from any voltage or current spikes that might be associated with the device being controlled, e.g. a pump motor starting. Further, it is possible to use a programmable time relay in order to ensure that the alarm does not go into a dithering state.

### **3.11 Interfacing the WS-16 with a Telephone Modem**

The WS-16 has a modem compatible firmware, which makes it possible to connect a standard telephone modem (with a speed capability of at least 9600 baud) between the WS-16 and a telephone line so that the WS-16 can be accessed remotely via telephone from a computer.

NovaLynx offers two modems, the 110-WS-16M for AC power and the 110-WS-16MDC for DC power. These modems have been tested with the WS-16 and are recommended.

The serial cable (with a null modem adapter) from the WS-16 is plugged into the external modem. The modem must be configured to auto answer. The modem is then plugged into a telephone line and is ready to be called from a remote location.

The remote computer also requires a standard telephone modem (with a speed capability of at least 9600 baud), and a communications program such as HyperTerminal or Procomm must be installed. The modem may need reconfiguration to communicate with the WS-16. The communications parameters are ANSI, 9600, 8-N-1. The modem may also need to be set up with a specific dialing string to establish communications at 9600 baud. See the modem documentation for specific instructions.

When the remote computer calls the WS-16, the WS-16's modem will go off-hook and the WS-16 will begin transmitting to the remote computer. All of the WS-16's functions are available from the remote computer. This includes observing real time data, looking at the hourly or daily logs, downloading data, and changing setup parameters such as the logging interval.

When disconnecting, leave the WS-16 running in the row and column or observation screen display.

## 4.0 SPECIFICATIONS

### Data Acquisition Module

Reporting units: English or Metric,  
all measurements  
Operating power: 10-16 Vdc  
Power consumption: 60 mA maximum  
Serial port: 9-pin d-sub connector,  
selectable baud rate, flow control  
Memory: 128KB RAM, nonvolatile (45 days at  
15 minute intervals with 6 sensors)  
expandable to 256KB or 512KB

### Wind Speed

Range: 0 to 125 mph (0-57 m/s)  
Resolution: > 0.1 mph  
Accuracy:  $\pm 1$  mph  
Starting threshold: 0.8 mph  
Time constant: 2 seconds

### Wind Direction

Range: 0-360°  
Resolution: > 1°  
Accuracy:  $\pm 3\%$   
Starting threshold:  
200-WS-02E: 1.2 mph  
200-WS-05E: 0.5 mph

### Temperature

Range: -40° to +140° F  
Resolution: > 0.1° F  
Accuracy:  $\pm 1^\circ$  F

### Relative Humidity

Range: 0-100% RH  
Accuracy:  $\pm 3\%$  (10-90%)

### Operating Temperature

Transducers: -40° to 140° F (-40° to 60° C)  
Module: -40° to 140° F (-40° to 60° C)

### Timekeeping

Format: MM/DD and HH:MM  
Accuracy:  $\pm 30$  seconds/month

### Barometric Pressure

Range: 28.25 to 30.75 inches Hg  
(956.6 to 1041.3 mb)  
Measurement span: 2.50 inches Hg (85 mb)  
Resolution:  $\pm 0.01$  inch Hg or  $\pm 0.3$  mb  
Altitude offset: 0 to +10,000 feet,  
screwdriver adjustable  
Absolute Accuracy: 0.05 inches Hg

### Rain Gauge

Resolution: 0.01"/tip  
Accuracy:  $\pm 4\%$  up to 3"/hour  
Max rate: Unlimited

### Solar Radiation (optional)

Sensor: Silicon pyranometer  
Spectral range: 0.4 to 1.1 microns  
Sensitivity: 80mV / 1000Wm<sup>2</sup> approx  
Accuracy:  $\pm 5\%$

## 5.0 ORDERING INFORMATION

### **WS-16 Modular Weather Station**

- 110-WS-16D Data Acquisition Module in Desktop Enclosure  
*includes set-up disk and 6' serial cable*
- 200-WS-02E Wind Speed/Direction Sensor, 40' cable
- 110-WS-16TH Outdoor Temperature & Relative Humidity Sensor, 40' cable
- 110-WS-16THS Solar Radiation Shield for temp/rh sensor
- 110-WS-16BP Barometric Pressure Sensor, 18" cable
- 110-WS-16RC Rain Gauge, includes mounting arm and 40' cable
- 110-WS-16TM 5' Tripod & 5' Sensor Mast (8' total)
- 110-WS-16P Power Supply, for desktop enclosure, 120Vac

### **WS-16 EPA High Sensitivity Modular Weather Station**

- 110-WS-16D Data Acquisition Module in Desktop Enclosure  
*includes set-up disk and 6' serial cable*
- 200-WS-05E High Sensitivity Wind Sensor, 40' cable
- 110-WS-16TH Outdoor Temperature & Relative Humidity Sensor, 40' cable
- 110-WS-16THS Solar Radiation Shield for temp/rh sensor
- 110-WS-16BP Barometric Pressure Sensor, 18" cable
- 110-WS-16RC Rain Gauge, includes mounting arm and 40' cable
- 110-WS-16TM 5' Tripod & 5' Sensor Mast (8' total height)
- 110-WS-16P Power Supply, for desktop enclosure, 120Vac

### **WS-16 Modular Weather Station in NEMA Enclosure with Solar Panel**

- 110-WS-16N-A Data Acquisition Module in NEMA Enclosure  
*includes battery, solar panel battery charger, mast mounting hardware, set-up disk, and 6' serial cable*
- 200-WS-02E Wind Speed/Direction Sensor, 40' cable
- 110-WS-16TH Outdoor Temperature & Relative Humidity Sensor, 40' cable
- 110-WS-16THS Solar Radiation Shield for temp/rh sensor
- 110-WS-16BP Barometric Pressure Sensor, 18" cable
- 110-WS-16RC Rain Gauge, includes mounting arm and 40' cable
- 110-WS-16TM 5' Tripod & 5' Sensor Mast (8' total height)

### **WS-16 Modular Weather Station in NEMA Enclosure with 115 Vac Charger**

- 110-WS-16N-B Data Acquisition Module in NEMA Enclosure  
*includes battery, 115Vac battery charger, mast mounting hardware, set-up disk, and 6' serial cable*
- 200-WS-02E Wind Speed/Direction Sensor, 40' cable
- 110-WS-16TH Outdoor Temperature & Relative Humidity Sensor, 40' cable
- 110-WS-16THS Solar Radiation Shield for temp/rh sensor
- 110-WS-16BP Barometric Pressure Sensor, 18" cable
- 110-WS-16RC Rain Gauge, includes mounting arm and 40' cable
- 110-WS-16TM 5' Tripod & 5' Sensor Mast (8' total height)

### **WS-16 Modular Weather Station in NEMA Enclosure with 220 Vac Charger**

- 110-WS-16N-C Data Acquisition Module in NEMA Enclosure  
*includes battery, 220Vac battery charger, mast mounting hardware, set-up disk, and 6' serial cable*
- 200-WS-02E Wind Speed/Direction Sensor, 40' cable
- 110-WS-16TH Outdoor Temperature & Relative Humidity Sensor, 40' cable
- 110-WS-16THS Solar Radiation Shield for temp/rh sensor
- 110-WS-16BP Barometric Pressure Sensor, 18" cable
- 110-WS-16RC Rain Gauge, includes mounting arm and 40' cable
- 110-WS-16TM 5' Tripod & 5' Sensor Mast (8' total height)

## **Options**

110-WS-16CC Carrying Case  
110-WS-16HHD Hand Held PC for local display of real time data  
110-WS-16M2 Memory Expansion to 256KB  
110-WS-16M5 Memory Expansion to 512KB  
110-WS-16M Telephone Modem  
110-WS-16MDC Telephone Modem, 12 Vdc  
110-WS-16PE Power Supply, for desktop enclosure, 220Vac  
110-WS-16PBU Battery Backup 120V, for desktop enclosure  
110-WS-16PBU-2 Battery Backup 220V, for desktop enclosure  
110-WS-16SML Display Software  
110-WS-16SMM Met Manager Software  
110-WS-16STR Graphical Display Software  
110-WS-16STR-H HTML Option  
110-WS-16CAO CAMEO/ALOHA Output Format  
110-WS-16SR Solar Radiation Sensor, includes mounting arm and 40' cable  
110-WS-16T Auxiliary Air Temperature Sensor, 40' cable  
110-WS-16TWS Water or Soil Temperature Sensor, 40' cable  
260-2501 Tipping Bucket Rain Gauge, 25' cable  
330-0220 Additional Cable for rain, per foot  
330-0424 Additional Cable for wind, per foot  
330-0524 Additional Cable for temp/humidity, per foot

Wireless radio communication packages are available for use with the WS-16.

## APPENDIX 1 Sensor Configuration

The **WS-16** is configured at the factory for the sensors it is shipped with. The following instructions are provided to aid the user in making changes to the standard setup.

### Wind Speed and Direction

Connect the wind sensor cable to the terminal strip on the back of the data acquisition module. This sensor has a four conductor shielded cable. The RED wire is connected to the +5 REF terminal; The BLACK wire is connected to a GROUND terminal; the GREEN wire (wind direction signal) is connected to the A7 terminal and the WHITE wire (wind speed signal) is connected to the P1 terminal. The WS-16 is now ready for wind speed and wind direction initializing.

#### INITIALIZATION OF WIND SPEED AND DIRECTION SENSORS

Press "M" and "Enter" to get the main menu.

From the main menu press "1", Station set up.

From the station set up menu press "6", Add or remove sensors. Then press "Y", then "Enter".

From the sensor types menu select "2", Wind Speed.

From the wind speed sensors menu select "1", 200-WS-01/02. Then press "Enter".

From the sensor input channel select "1", P1 (Pulse Counter). Then press "Enter".

The sensor configuration screen is displayed and it will show:

Sensor type	Model	Input	Calibration
Wind Speed	200-WS-01/02	P1	

If you intend to add another sensor select "A".

If you do not want to add another sensor select "Q".

You will be asked if you are sure that you want to erase memory.

If you have added or deleted a sensor select "Y" if not select "N" and press "Enter".

To initialize the wind direction sensor, press "M" and "Enter" to get the main menu.

From the main menu press "1", Station set up. Then press "Enter".

From the station set up menu press "6", Add or remove sensors. Then press "Y", then "Enter".

From the sensor type menu select "3", Wind Direction. Then press "Enter".

From the wind direction sensor menu select "1", 200-WS-02. Then press "Enter".

From the sensor input channel menu select "11", Analog Input A7. Then press "Enter".

The sensor configuration menu appears and it will show:

Sensor type	Model	Input	Calibration
Wind Speed	200-WS-01/02	P1	
Wind Direction	200-WS-02	A7	

If you intend to add another sensor select "A".

If you do not want to add another sensor select "Q".

You will be asked if you are sure that you want to erase memory.

If you have added or deleted a sensor select "Y" if not select "N" and press "Enter".

### **Temperature (thermistor) and Relative Humidity (capacitive sensor)**

Connect the combination temperature and relative humidity sensor cable to the terminal strip on the back of the data acquisition module. This sensor has a five conductor cable. The RED wire is connected to the +12 REF terminal. The BLACK wire is connected to a GROUND terminal. The BROWN wire (humidity signal) is connected to the A4 terminal. The WHITE (temperature signal) is connected to the A5 terminal and the GREEN wire is connected to a GROUND terminal.

### **INITIALIZATION OF TEMPERATURE AND RELATIVE HUMIDITY**

Press "M" and "Enter" to get the main menu.

From the main menu press "1", Station set up.

From the station set up menu press "6", Add or remove sensors. Then press "Y", then "Enter".

From the sensor type menu select "4", Temperature. Then press "Enter".

From the temperature sensors menu select "2", 225-501/WS-16TH. Then press "Enter".

The menu then asks: Enter temperature offset or press Q to quit. Press "Q".

From the sensor input channel menu select "9", A5. Then press "Enter".

If you intend to add another sensor select "A".  
If you do not want to add another sensor select "Q".  
You will be asked if you are sure that you want to erase memory.  
If you have added or deleted a sensor select "Y" if not select "N" and press "Enter".

If you selected A to add the relative humidity sensor then press "Y", then "Enter".

From the sensor types menu select "5", Humidity.

From the humidity sensors menu select "1", 110-WS-16TH. Then press "Enter".

From the sensor input channel select "8", A4. Then press "Enter".

The sensor configuration menu appears and it will show:

Sensor type	Model	Input	Calibration
Humidity	110-WS-16TH	A4	
Temperature	225-501/-WS-16T	A5	

If you intend to add another sensor select "A".  
If you do not want to add another sensor select "Q".  
You will be asked if you are sure that you want to erase memory.  
If you have added or deleted a sensor select "Y" if not select "N" and press "Enter".

## **Barometric Pressure**

Connect the barometric pressure sensor cable to the terminal strip on the data acquisition module. This sensor has a three conductor cable. The RED wire is connected to a +12V terminal. The BLACK wire is connected to a GROUND terminal and the GREEN wire is connected to terminal A2.

### INITIALIZATION OF THE BAROMETRIC PRESSURE SENSOR

Press "M" and "Enter" to get the main menu.

From the main menu press "1", Station setup.

From the station set up menu press "6", Add or remove sensors. Then press "Y", then "Enter".

From the sensor type menu select "6", Pressure. Then press "Enter".

From the pressure sensors menu select "1", 100-WS-16BP. Then press "Enter".

The menu asks: Enter pressure offset or press Q to quit. Press "Q".

The sensor configuration menu appears and it will show:

Sensor type	Model	Input	Calibration
Pressure	100-WS-16BP	A2	

If you intend to add another sensor select "A".

If you do not want to add another sensor select "Q".

You will be asked if you are sure that you want to erase memory.

If you have added or deleted a sensor select "Y" if not select "N" and press "Enter".

## Rain Gauge

Connect the rain gauge cable to the terminal strip on the data acquisition module. This sensor has a two conductor cable. Connect one conductor to a GROUND terminal and the other conductor to terminal P3.

### INITIALIZATION OF THE RAIN GAUGE

Press "M" and "Enter" to get the main menu.

From the main menu press "1", Station setup.

From the station set up menu press "6", Add or remove sensors. Then press "Y", then "Enter".

From the sensor type menu select "7", Precipitation.

From the precipitation menu select "1", All models. Then press "Enter".

From the sensor input channel select "3", Pulse Counter 3. Then press "Enter".

The screen directs you to: Enter tip resolution or press [Q] to quit. For English units, use 0.01. For metric units, use 0.254. Then press "Enter".

The sensor configuration menu appears and it will show:

Sensor type	Model	Input	Calibration
Precipitation	All models	P3	0.01

**Note:** Changing units on the setup menu will not change the reported value for rainfall. That change must be made from the add or remove sensors menu.

If you intend to add another sensor select "A".

If you do not want to add another sensor select "Q".

You will be asked if you are sure that you want to erase memory.

If you have added or deleted a sensor select "Y" if not select "N" and press "Enter".



### **Auxiliary Temperature (Optional Sensor)**

The auxiliary temperature sensor is a thermistor attached to a two conductor cable. Connect one conductor to A6 terminal and the other conductor to a GROUND terminal.

#### INITIALIZATION OF THE AUXILIARY TEMPERATURE SENSOR

Press "M" and "Enter" to get the main menu.

From the main menu press "1", Station setup.

From the station set up menu press "6", Add or remove sensors. Then press "Y", then "Enter".

From the sensor type menu select "4", Temperature. Then press "Enter".

From the temperature sensors menu select "1", 100-WS-16T. Then press "Enter".

The menu then asks: Enter temperature offset or press Q to quit. Press "Q".

From the sensor input channel menu select number "A6". Then press "Enter".

If you intend to add another sensor select "A".

If you do not want to add another sensor select "Q".

You will be asked if you are sure that you want to erase memory.

If you have added or deleted a sensor select "Y" if not select "N" and press "Enter".

### **Solar Radiation (Optional Sensor)**

Connect the solar radiation sensor to the terminal strip on the back of the data acquisition module. This sensor has a two wire cable. Attach the WHITE conductor to the A1 terminal and the BLACK conductor to a GROUND terminal.

#### INITIALIZATION OF THE SOLAR RADIATION SENSOR

Press "M" and "Enter" to get the main menu.

From the main menu press "1", Station setup.

From the station set up menu press "6", Add or remove sensors. Then press "Y", then "Enter".

From the sensor type menu select "8", Solar Radiation. Then press "Enter".

From the solar radiation menu select "1", 240-120/WS-16SR. Then press "Enter".

Enter the calibration factor from the calibration sheet, which was supplied with the sensor. Then press "Enter".

From the sensor input channel menu select number "A1". Then press "Enter".

The sensor configuration menu appears and it will show:

Sensor type	Model	Input	Calibration
Solar Radiation	240-120/WS-16SR	A1	74

If you intend to add another sensor select "A".

If you do not want to add another sensor select "Q".

You will be asked if you are sure that you want to erase memory.

If you have added or deleted a sensor select "Y" if not select "N" and press "Enter".

### WS-16 SENSOR HOOK-UP DIAGRAM

