

# Micro Response Anemometer Model 2030

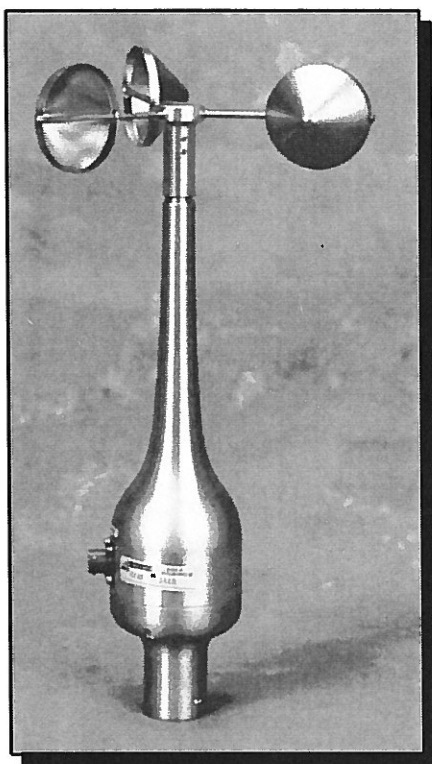

User's  
Manual

**NovaLynx**

PO Box 240  
Grass Valley, CA 95945-0240  
(530) 823-7185



1165 National Drive • Sacramento, CA 95834 • 800.824.5873

---

# Introduction

The Model 2030 Micro Response Anemometer is a highly responsive three cup anemometer that uses a photon-coupled chopper to produce an output pulse with a frequency proportional to wind speed.

The threshold of the anemometer is 1 mile per hour.

The entire anemometer assembly, with the exception of the photon-coupled chopper, is made from stainless steel and anodized aluminum.

A quick release waterproof connector is provided.

The Model 2030 Anemometer can be used in conjunction with several interfaces:

- All Weather Inc.'s Q-Net data acquisition system

- All Weather Inc.'s Automated Weather Observing System (AWOS), interfaced to the Model 1798 Sensor Interface Processor (SIP)

- 1190 series data acquisition systems

- Model 1220 or Model 1280 Wind Speed Signal Conditioning Modules, which provide an analog output proportional to wind speed

---

# Contents

Installation .....	1
Assembly .....	1
Site Selection .....	1
Mounting .....	2
Orientation .....	2
Theory of Operation .....	3
Calibration .....	4
Maintenance .....	5
Inspecting the Bearings .....	5
Precautions .....	5
Replacing the Bearings .....	5
Maintenance Kit .....	6
AWOS Periodic Maintenance .....	6
Tools and Equipment Required .....	6
Monthly Maintenance .....	6
Quarterly Maintenance .....	6
Annual Maintenance .....	6
Warranty .....	8
Specifications .....	9
Drawings and Parts List .....	10

# Installation

This instrument is thoroughly tested and fully calibrated at the factory and is ready for installation. Please refer to the return authorization card included in the packing box if damage has occurred. Also, notify All Weather Inc.

## Assembly

With the exception of installing the cup assembly, the Model 2030 Micro Response Anemometer is ready for mounting. Install the cup assembly as described in the steps below.

Loosen the two set screws with a 1/16" allen wrench, and slide the cup assembly over the anemometer shaft. Be certain that the flat face of the shaft faces toward the set screws.

The cup assembly hub should slide down over the shaft and body and seat against the shaft ring. When correctly in place, there should be about a 0.050 inch clearance between the skirt of the hub and the shoulder of the body. Tighten both set screws to 7 in. lbs.

Spin the cup wheel by hand to assure smooth operation. The cup wheel should coast to a smooth stop.

## Site Selection

Location of the sensor is critical for accurate wind measurements. The standard exposure of an anemometer or vane over open, level terrain is 10

meters above the ground. Open, level terrain is defined as level ground with no obstruction within 300 meters. In locations where obstructions are not large, such as residential areas, and are distributed more or less evenly, the sensor may be placed at an effective height of  $h + 10$  meters, where  $h$  is the approximate height (in meters) of the various obstacles. As an example, in a location where trees and buildings reach to about 5 meters, the sensors must be placed on a 15 meter mast to avoid erroneous results.

In areas where large obstructions do exist within 300 meters of the sensor, the following table can be used to calculate the proper height of the sensor ( $h$  is the height of the obstruction).

**Example:** If there is a building 10 meters high and 50 meters away, the anemometer should be at least 16.7 meters above the ground. But, if the same building is 200 meters away, the sensor could be lowered to 12.5 meters.

When the sensor is mounted on a building, the building itself disturbs the wind flow and must be taken into account before installation. For large buildings, other than buildings such as lighthouses and skyscrapers, the sensor must be mounted as far away from the edge of the building as possible and at a height **at least  $\frac{3}{4}$  the height of the building**. Thus, with a building 28 meters high, a rooftop tower at least 21 meters high should be used.

Distance to obstruction	Minimum height above ground level of anemometer
$h$	$1.75h$ to $2.25h$
$5h$	$1.67h$
$10h$	$1.50h$
$20h$	$1.25h$
$25h$	$1.13h$
$30h$	$h$

**Table 1<sup>1</sup>**

<sup>1</sup> Handbook of Meteorological Instruments, 2nd Edition. Measurement of Surface Wind, Volume 4. London, HMSO: 1981

## Mounting

The Model 2030 Micro Response Contact Anemometer mounts directly to the Model 2023 Crossarm without any additional accessories. The crossarm is generally used to mount one each Model 2030 Anemometer and a Model 2020 Vane to form a wind speed and direction measurement set. If the Model 2030 Anemometer is to be mounted separately, a Model 20231 Mast Adapter should be ordered as an accessory. Both the Model 2023 Crossarm and the Model 20231 Mast Adapter will mount on a mast with an outside diameter of 1" (25.4 mm) or 3/4" Schedule 40 pipe. Set screws are provided in either case for securing to the mast. The lower part of the anemometer body will slip over the pin on the crossarm or the mast adapter. When in place, tighten all mounting screws.

For AWOS installations, refer to the **2020/2030 AWOS Mounting** figure in the *Drawings* chapter of this manual.

## Orientation

The anemometer should be mounted with its axis as close to vertical as possible to provide for the best measurement of horizontal wind movement. If the sensor must be removed from the mounting adapter or crossarm, loosen only the allen head screw on the sensor base and slide the sensor off the adapter. Do not remove the mounting pin from the crossarm or the mast adapter from the mast, since these serve to maintain sensor alignment.

Install a four-wire 20 AWG cable in the mating connector using care in soldering and cable dressing. Replace the connector back shell to form a waterproof assembly. The connector is a quick release type and requires only a quarter turn of the nut to lock in place. Do not tighten with a wrench. Connections are as shown in Figure 1.

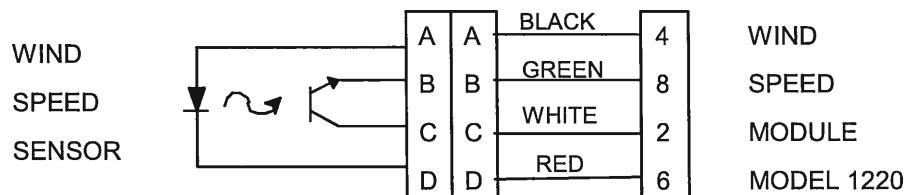

FIGURE 1

---

# Theory of Operation

A light emitting diode in combination with a light sensitive transistor is mounted directly to the anemometer connector. A slotted wheel connected to the anemometer shaft rotates with the shaft and interrupts the light beam between the light emitting diode and the phototransistor. This interruption causes a change in the transistor's collector to emitter current.

The current changes are amplified and conditioned by the Model 1220 Wind Speed Signal Conditioning Module, which provides an analog output signal proportional to wind speed.

# Calibration

The slotted wheel contains 30 slots, providing thirty electrical pulses per revolution. The output frequency of the anemometer may be determined by the following equation:

$$F_{Hz} = 9.901(V_{mph} - 0.746)$$

Or the velocity may be determined as follows:

$$V_{mph} = F_{Hz} / 9.901 + 0.746$$

$$V_{knots} = F_{Hz} / 11.395 + 0.648$$

where  $F_{Hz}$  is the frequency in Hertz,  $V_{mph}$  is the velocity in miles/hour, and  $V_{knots}$  is the velocity in knots.

Calibration data in Table 2 was compiled from tests in which the anemometer was operated in a wind tunnel equipped with NBS-traceable measuring instruments.

The Model 1220 Wind Speed Signal Conditioning Module is equipped with a calibration feature consisting of a constant frequency oscillator and a switch to apply the oscillator to the signal conditioning circuitry. This feature allows the operator to quickly set up the output signals for zero and full-scale values. Refer to the Model 1220 manual for additional information.

To verify calibration of the anemometer, rotate the anemometer shaft at one of the known rpm values shown in Table 1 and measure the sensor output with a frequency counter or oscilloscope. If a Model 1220 module is used, place the module into OPERATE mode and measure the frequency between the BLK/WHT and the BLK test points (TP110 and TP100). The measured frequency should equal the value indicated in the calibration table.

Frequency Hz	Shaft Speed rpm	Wind Speed mph	Wind Speed m/s	Wind Speed knots
25	50	3.27	1.46	2.84
30	60	3.78	1.69	3.28
150	300	15.90	7.11	13.82
450	900	46.20	20.65	40.14
750	1500	76.50	34.20	66.47
900	1800	91.65	40.97	79.64
983	1965	100.00	44.70	86.89
1100	2200	111.85	50.00	97.19

Miles Per Hour	Knots	Meters per Second	Feet per Second
mph x 0.868 = knots	knots x 1.152 = mph	m/s x 2.237 = mph	ft/s x 0.682 = mph
mph x 0.447 = m/s	knots x 0.515 = m/s	m/s x 1.943 = knots	ft/s x 0.592 = knots
mph x 1.467 = ft/s	knots x 1.689 = ft/s	m/s x 3.281 = ft/s	ft/s x 0.305 = m/s

---

# Maintenance

Maintenance of the sensor consists mainly of checking the bearings for wear, and replacing them as necessary.

For maintenance of a sensor as part of an AWOS system, refer to the *AWOS Periodic Maintenance* section below.

## Inspecting the Bearings

The anemometer bearings should be inspected for wear periodically. The bearings are sealed and protected to prevent dirt and moisture from entering. With time, however, the seals will no longer prevent dirt from entering the bearing race and the bearings may fail. When this happens, the sensor will no longer rotate freely. The bearings can be replaced in the field or the anemometer can be returned to All Weather Inc. for servicing.

To inspect the bearings, turn the anemometer cup assembly to check that it turns freely and smoothly. If it does not, replace the bearings as described below.

## Precautions

Since corrosion is the main problem associated with wind sensors, apply a thick coating of silicon lubricant to the connector shell after the connector is attached and in place. Also, use a non-corrosive lubricant such as bee's wax on all screws and fasteners whenever disassembly of the sensor is required. The use of these lubricants will make servicing of the sensor easier and will prevent seizure of the fastening hardware. It is also advisable to apply lubricant to the mounting adapter surfaces prior to final sensor installation. A commercial grade lubricant recommended for use is DOOR-EASE, available at hardware and automotive stores. In addition to these precautions, check that the drain hole in the base of the sensor is free of debris so that water drains away rather than collecting within the sensor.

## Replacing the Bearings

Follow the steps below to replace the bearings in the field.

- 1 Remove the cup wheel with a 1/16" allen wrench.
- 2 Remove the electrical receptacle/photon coupled chopper assembly by removing the four 4-40 screws and sliding the entire unit out.
- 3 Remove the lower body section by removing three 6-32 screws.
- 4 Remove the E-clip from the shaft at the top of the unit and slide the entire shaft down and out of the unit, taking care not to bend the shaft.
- 5 Lift the upper bearing out by working a knife edge under the flanged outer race.
- 6 Using a rod of about 1/4" diameter passed down from the top, carefully knock the lower bearing out.
- 7 Clean all parts and install new bearings. Press the bearings in place by applying pressure to the outer race only. The bearing could be damaged by pressing against the inner race.
- 8 Re-assemble all parts in the reverse order of disassembly. Check for free and smooth rotation of the shaft before and after installing the cup wheel. The receptacle/photon-coupled chopper assembly should be installed with the large connector key toward the top of the unit. Wipe the lens areas of the chopper clean with a soft cloth prior to re-assembly.
- 9 Should there be any problems with the photon-coupled chopper, replace the entire connector/chopper assembly. Check for proper excitation current polarity and phototransistor circuit polarity prior to connecting power to the new assembly.



Use great care in disassembly and re-assembly of the sensor. Never use excessive force to make parts fit together. Over-tightening of fasteners will either break the fastener or damage the machined threads of the sensor.

Any difficulties encountered during servicing that are not correctable by the user should be referred to the All Weather Inc. Customer Service Department.

### Maintenance Kit

A maintenance kit (P/N M488141) is available for the Model 2030 that provides the parts necessary for basic upkeep of the instrument. The kit includes those parts that are the most susceptible to wear, such as bearings and set screws. To order this kit, contact All Weather Inc. and specify Part Number M488141.

### AWOS Periodic Maintenance

Periodic maintenance of AWOS sensors is divided into three categories: monthly maintenance, quarterly maintenance, and annual maintenance. The listed maintenance routines are performed according to that schedule.

#### Tools and Equipment Required

- ½" wrench
- Silicon lubricant
- Non-corrosive lubricant (bee's wax)
- Model 1231 run-up motor

#### Monthly Maintenance

Monthly maintenance of the Model 2030 consists of visually verifying that the cups are moving freely and that the displayed wind speed is reasonable.

#### Quarterly Maintenance

Quarterly maintenance of the Model 2030 is identical to the monthly maintenance procedure: visually verify that the cups are moving freely and that the displayed wind speed is reasonable.

### Annual Maintenance

During annual maintenance, perform the following procedures in addition to those outlined for monthly and quarterly maintenance.

- 1 Set the DCP's LCD display to display wind speed, and verify that the displayed wind speed is reasonable.
- 2 Remove the anemometer cup assembly by loosening the set screw on the side of the cup assembly collar.
- 3 Connect a Model 1231 run-up motor to the anemometer shaft and power the motor on. The DCP's LED display should read between 79 and 81 knots.
- 4 Replace the cup assembly.
- 5 Inspect the anemometer cups for damage, and replace if necessary.
- 6 *(The following test should be performed in windless conditions. If one person is performing the test alone, the anemometer will need to be removed from the tower and connected to a test cable within sight of the DCP display.)*

With the cup assembly in place, spin the cups by hand until the DCP display reads greater than 5 knots. After releasing the cups, they will slow and the displayed speed will gradually decrease. If the display reads 2 knots or less while the cups are still turning, the bearings are good. If the cups stop before slowing to a speed of 2 knots or less, replace the bearings.

- 7 Remove the sensor from the mounting bracket by loosening the clamp screw located at the base of the unit.
- 8 Clean the drain hole on the bottom of the sensor to ensure that debris does not prevent water from draining out of the sensor.

- 9** Spread non-corrosive lubricant such as bee's wax on the clamp screw and reinstall the sensor. The sensor mounting hole should be aligned with the pin on the base of the mounting bracket.
- 10** Inspect all mounting hardware and cable assemblies for wear and damage. Replace as necessary.
- 11** Apply a thick coating of silicon lubricant to the connector shell after the connector is attached and in place. Use a non-corrosive lubricant such as bee wax on all screws and fasteners. The use of these lubricants will make future servicing easier.

---

# Warranty

Unless specified otherwise, All Weather Inc. (the Company) warrants its products to be free from defects in material and workmanship under normal use and service for one year from date of shipment, subject to the following conditions:

- a. The obligation of the Company under this warranty is limited to repairing or replacing items or parts which have been returned to the Company and which upon examination are disclosed, to the Company's satisfaction, to have been defective in material or workmanship at time of manufacture.
- b. The claimant shall pay the cost of shipping any part or instrument to the Company. If the Company determines the part to be defective in material or workmanship, the Company shall prepay the cost of shipping the repaired instrument to the claimant. Under no circumstances will the Company reimburse claimant for cost incurred in removing and/or reinstalling replacement parts.

- c. This warranty shall not apply to any Company products which have been subjected to misuse, negligence, or accident.
- d. This warranty and the Company's obligation thereunder is in lieu of all other warranties, express or implied, including warranties of merchantability and fitness for a particular purpose, consequential damages, and all other obligations or liabilities.

No other person or organization is authorized to give any other warranty or to assume any additional obligation on the Company's behalf, unless made in writing and signed by an authorized officer of the Company.

---

# Specifications

Threshold .....	<1 mph
Accuracy .....	±.15 mph or 1%
Distance constant .....	5 feet
Range .....	0-160 mph or 0-71 m/s
Operating temperature range .....	-40 to +60°C
Cup material .....	Carbon/Graphite composite
Turning radius .....	3.8"
Body size .....	12"H x 2 <sup>3</sup> / <sub>4</sub> " diameter (305 x 70 mm)
Weight/Shipping .....	2.5 lbs/7 lbs (1.1 kg/3.2 kg)
Mounting .....	Direct to crossarm or with adapter to 1" (25.4 mm) O.D. mast
Photon chopper current .....	20 mA

*Optional heaters available*

---

# Drawings and Parts List

The following pages include reference drawings and a parts list to assist in installation and maintenance of this instrument.

REV	EDN	REVISIONS DESCRIPTION	DATE	APPROVED
B	-	-	9-83	
C	-	-	1-83	
D	4251	ADD DETAIL A, LABELS, NOTES 1 THRU 8	10-4-93	SP
E	4538	DELETED ITEM 1 CONNECTOR AND ITEM 8 SET SCREW, ADDED ITEM 8, 10, 11, 2X & NOTE 9 & 10	21NOV85	KAH
F	4738	ADD CE LABEL 11-21 & NOTE 11		

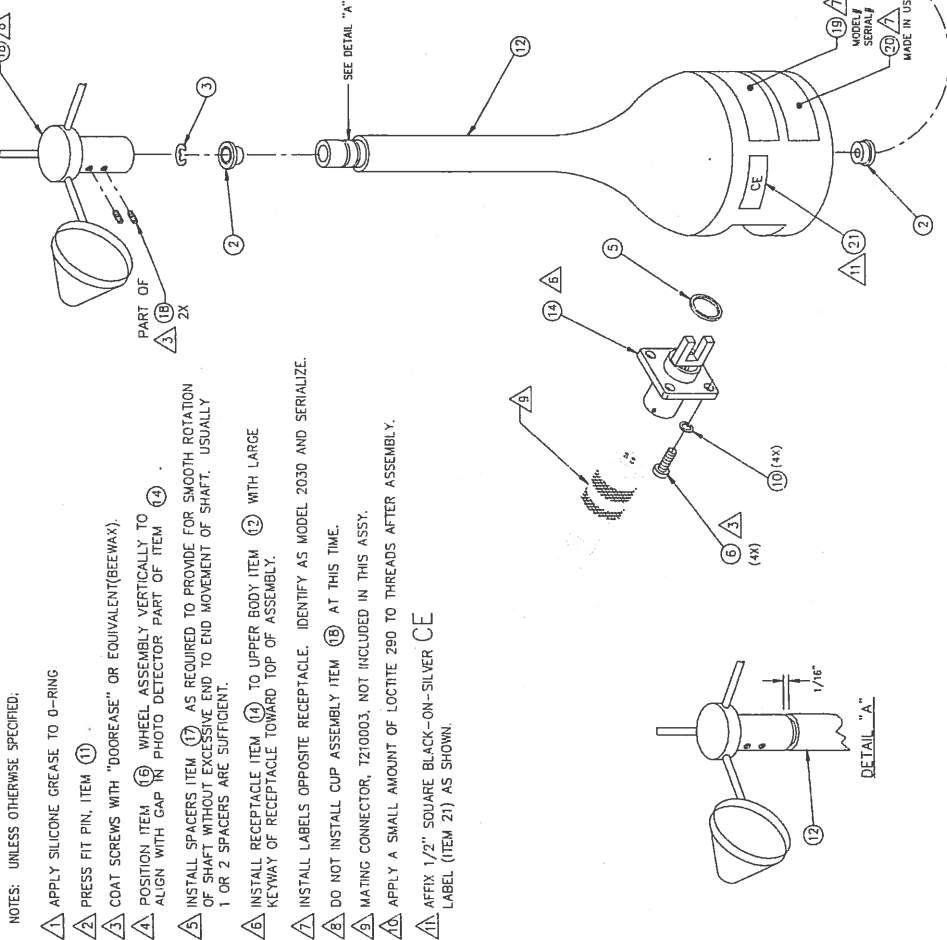

NOTES: UNLESS OTHERWISE SPECIFIED:

- 1. APPLY SILICONE GREASE TO O-RING
- 2. PRESS FIT PIN, ITEM 1
- 3. COAT SCREWS WITH "DOOREASE" OR EQUIVALENT(BEEWAX).
- 4. POSITION ITEM 5 WHEEL ASSEMBLY VERTICALLY TO ALIGN WITH GAP IN PHOTO DETECTOR PART OF ITEM 14
- 5. INSTALL SPACERS ITEM 17 AS REQUIRED TO PROVIDE FOR SMOOTH ROTATION OF SHAFT WITHOUT EXCESSIVE END TO END MOVEMENT OF SHAFT. USUALLY 1 OR 2 SPACERS ARE SUFFICIENT.
- 6. INSTALL RECEPTACLE ITEM 4 TO UPPER BODY ITEM 12 WITH LARGE KEYWAY OF RECEPTACLE TOWARD TOP OF ASSEMBLY.
- 7. INSTALL LABELS OPPOSITE RECEPTACLE. IDENTIFY AS MODEL 2030 AND SERIALIZE.
- 8. DO NOT INSTALL CUP ASSEMBLY ITEM 18 AT THIS TIME.
- 9. MATING CONNECTOR, T210003, NOT INCLUDED IN THIS ASSY.
- 10. APPLY A SMALL AMOUNT OF LOCTITE 290 TO THREADS AFTER ASSEMBLY.
- 11. AFFIX 1/2" SQUARE BLACK-ON-SILVER CE LABEL (ITEM 21) AS SHOWN.

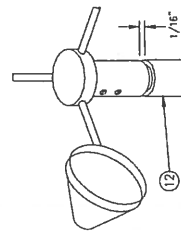

EXCEPT AS MAY OTHERWISE BE SPECIFIED BY CONTRACT, THIS DOCUMENT AND THE DATA DISCLOSED HEREIN ARE UNCLASSIFIED INFORMATION AND NOT TO BE DISCLOSED IN WHOLE OR IN PART TO ANYONE WITHOUT THE WRITTEN PERMISSION OF QUALMETRICS, INC.

APPEND THE FOLLOWING DOCUMENTS WHEN CHANGING THIS DOCUMENT		UNLESS OTHERWISE SPECIFIED, DIMENSIONS ARE IN INCHES UNLESS SHOWN OTHERWISE. DO NOT SCALE DRAWING.		QUALMETRICS	
2030-001		DATE	REVISION	DATE	REV
				9-82	1 OF 1
DRAWN BY: KODYMAN		DATE: 29 JUL 93		TITLE: ASSEMBLY DRAWING, MICRO RESPONSE ANEMOMETER, MODEL 2030	
REVIEWED BY: P. KODYMAN		DATE: 19 AUG 97		QUALMETRICS	
CHECKED BY:		DATE: 11-21-95		PROJECT MANAGER: J. CONNER	
DESIGN ENGINEER:		DATE:		PROJECT MANAGER:	
AS ISSUED		DATE:		PROJECT MANAGER:	
TREATMENT:		DATE:		PROJECT MANAGER:	
APPROVALS:		DATE:		PROJECT MANAGER:	

REV		DESCRIPTION		DATE		APPROVED	
A	4163	INITIAL RELEASE		9-8-93		SP	
B	4805	CHANGE U-BOLTS		11/2/98		CSP	
C	4981	ADD FOLDOVER TOWER VERSION SHIT 2					

REV		DESCRIPTION		DATE		APPROVED	
A	4163	INITIAL RELEASE		9-8-93		SP	
B	4805	CHANGE U-BOLTS		11/2/98		CSP	
C	4981	ADD FOLDOVER TOWER VERSION SHIT 2					

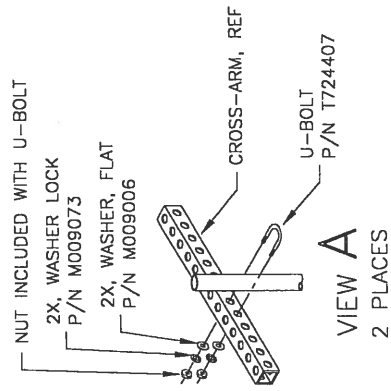
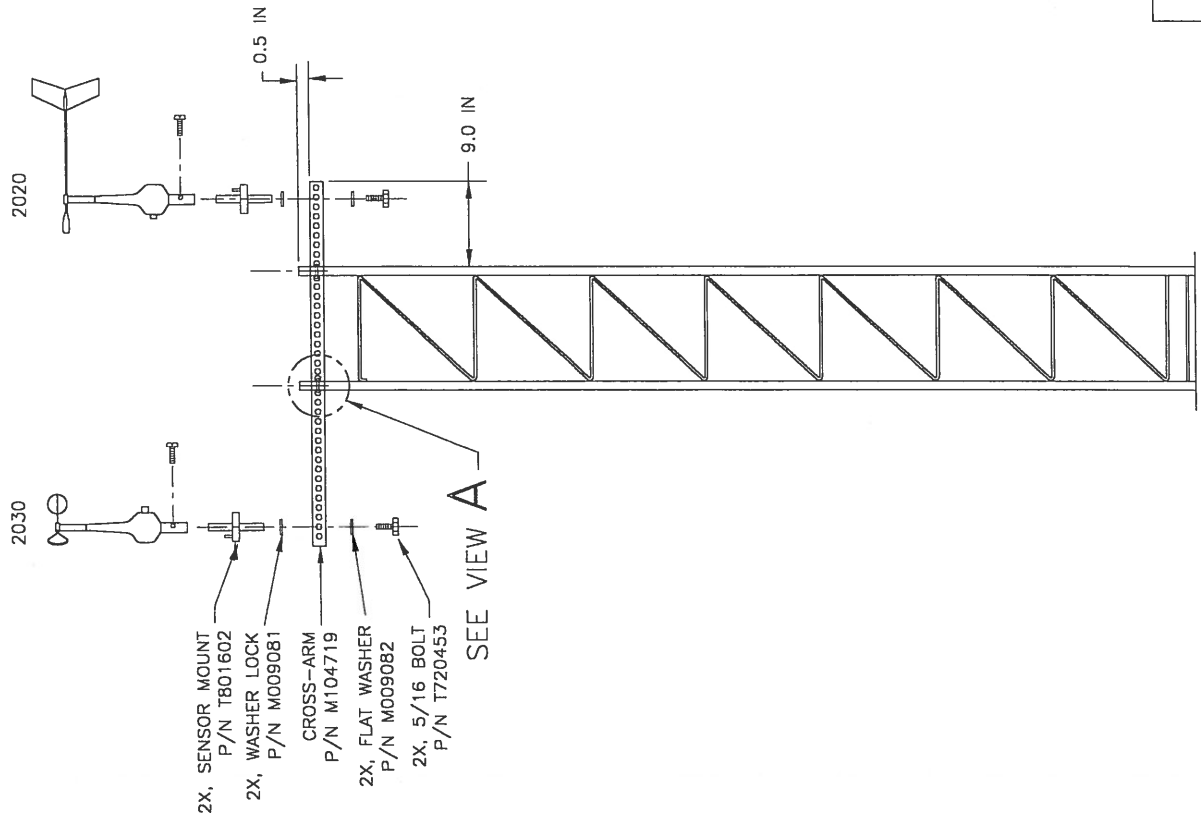

EXCEPT AS MAY OTHERWISE BE SPECIFIED BY CONTRACT, THIS DOCUMENT AND THE DATA DISCLOSED HEREIN AND HEREWITH, IS NOT TO BE USED, REPRODUCED OR DISCLOSED, IN WHOLE OR IN PART, TO ANYONE WITHOUT THE WRITTEN PERMISSION OF ALL WEATHER INC.

A	C	REV	REV STATUS
2	1	SHEET	OF SHEETS

UNLESS OTHERWISE SPECIFIED: DIMENSIONS ARE IN INCHES XX = ±.010 TOLERANCES XXX = ±.005 FRACTIONS = 1/2" DO NOT SCALE DRAWING		DRAWN BY: KOOYMAN	7SEP93	TITLE ASSEMBLY DRAWING, CROSSARM, 2020, 2030, AWOS	
MATL SEE PARTS LIST	DESIGN ENGINEER:	CHECKED BY: KOOYMAN	23SEPT03	SIZE C	
FINISH AS ISSUED	PROGRAM MANAGER: JM ANDERSON	APPROVALS	8SEP93	SCALE NONE	RELEASE DATE 8SEP93 SHEET 1 OF 2
TREATMENT					

2020/2030  
AWOS MOUNTING  
(STACKED TOWER)

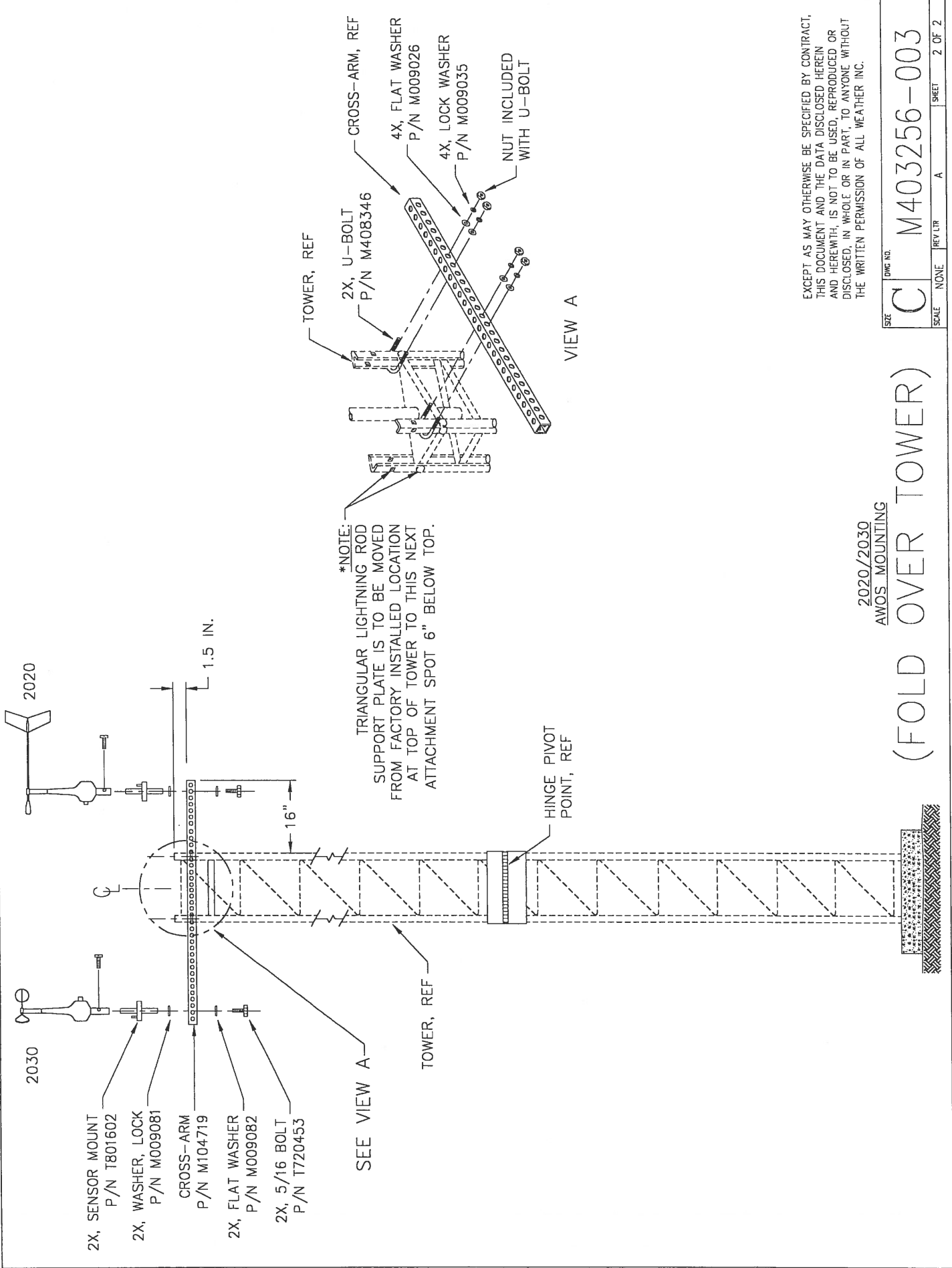

\*NOTE:  
 TRIANGULAR LIGHTNING ROD  
 SUPPORT PLATE IS TO BE MOVED  
 FROM FACTORY INSTALLED LOCATION  
 AT TOP OF TOWER TO THIS NEXT  
 ATTACHMENT SPOT 6" BELOW TOP.

VIEW A

EXCEPT AS MAY OTHERWISE BE SPECIFIED BY CONTRACT,  
 THIS DOCUMENT AND THE DATA DISCLOSED HEREIN  
 AND HEREWITH, IS NOT TO BE USED, REPRODUCED OR  
 DISCLOSED, IN WHOLE OR IN PART, TO ANYONE WITHOUT  
 THE WRITTEN PERMISSION OF ALL WEATHER INC.

2020/2030  
 AWOS MOUNTING

(FOLD OVER TOWER)

SIZE	DWG NO.	SHEET
C	M403256-003	2 OF 2
SCALE	REV LTR	A
NONE		



REVIEWS		2030-004
REV	ECN	DESCRIPTION
A	2468	INITIAL RELEASE
B	4251	REDRAWN, COMBINE SHT 1 & 2, CHG REV
C	4538	ECN UPDATE TO 4538 ONLY
		DATE
		1-86
		10-93

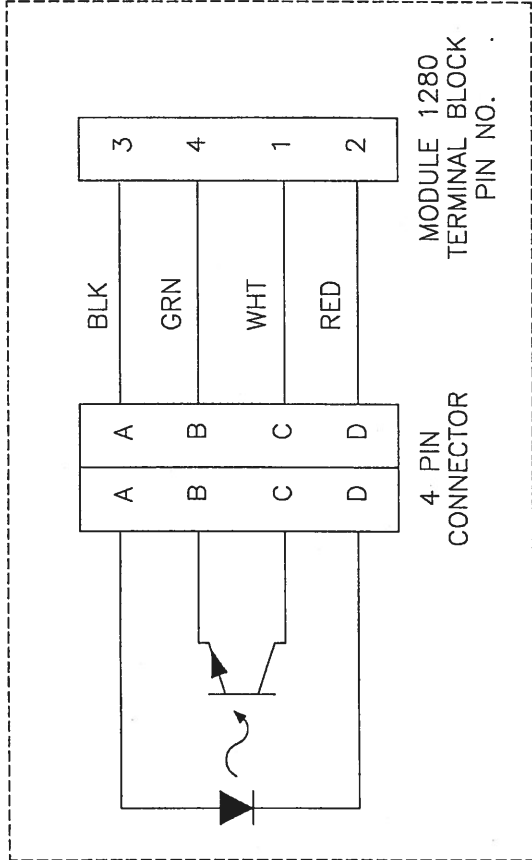
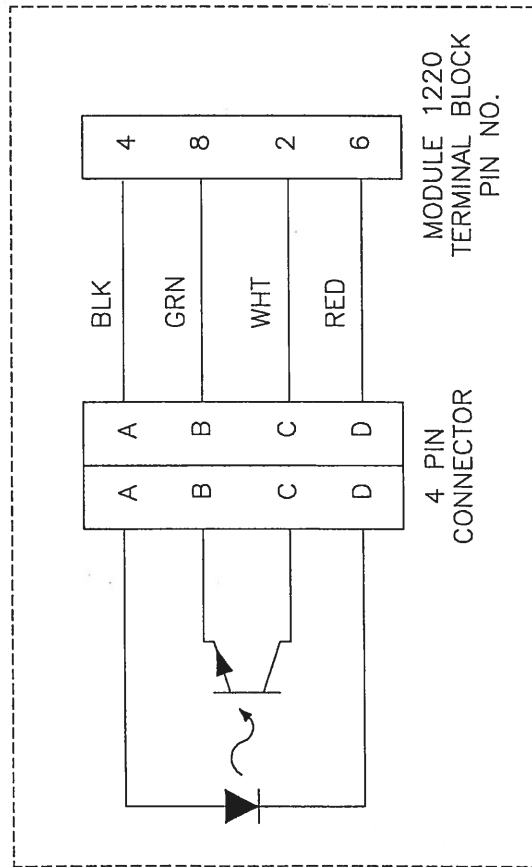

EXCEPT AS MAY OTHERWISE BE SPECIFIED BY CONTRACT, THIS DOCUMENT AND THE DATA DISCLOSED HEREIN AND HEREWITH, IS NOT TO BE USED, REPRODUCED OR DISCLOSED, IN WHOLE OR IN PART, TO ANYONE WITHOUT THE WRITTEN PERMISSION OF QUALIMETRICS, INC..

APPEND THE FOLLOWING DOCUMENTS WHEN CHANGING THIS DOCUMENT: 2030-001		UNLESS OTHERWISE SPECIFIED: DIMENSIONS ARE IN INCHES TOLERANCES XX=±0.010 ANGLES ±1/2° XXX=±0.005 FRACTIONS=±.02 DO NOT SCALE DRAWING	DRAWN BY: KOOTYMAN	5AUG93	TITLE
		MATL	REVISED BY: J. CONNER	12SEP95	SCHEMATIC DRAWING, MICRO RESPONSE, ANEMOMETER, PHANTON CHOPPER
		SEE BILL OF MATERIALS	CHECKED BY:		QUALIMETRICS
		FINISH	DESIGN ENGINEER:		DWG NO.
		TREATMENT	PROJECT MANAGER:		2030-004
			APPROVALS	DATE	SIZE
					B
					SCALE
					NONE
					RELEASE DATE
					SHEET
					1 OF 1

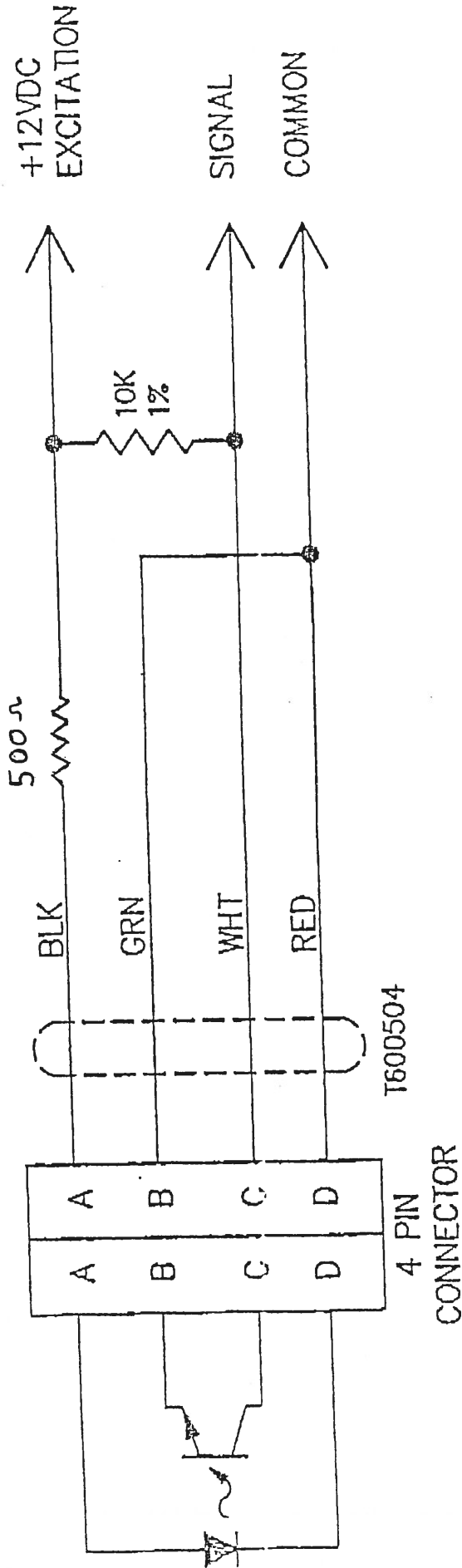

REV		ECN	DATE	QTY	NEXT ASSY	TOLERANCES UNLESS OTHERWISE NOTED XXX=±.005 XX=±.010 FRACTIONS=±.02 ANGLES ±1/2° CONCENTRICITY=.003 TIR		A	
A		3192	6-7-89			MATERIAL		TITLE SCHEMATIC, ANEMOMETER MODEL 2030, 3 WIRE CONFIGURATION	
						FINISH		MOD. USAGE	
						ENGR		BY <i>K. Weber</i>	
						APPROVED		DATE 6-7-89	
								SCALE <i>KL</i>	
								DWG. NO. 2030-025	
								SHEET 1 OF 1	

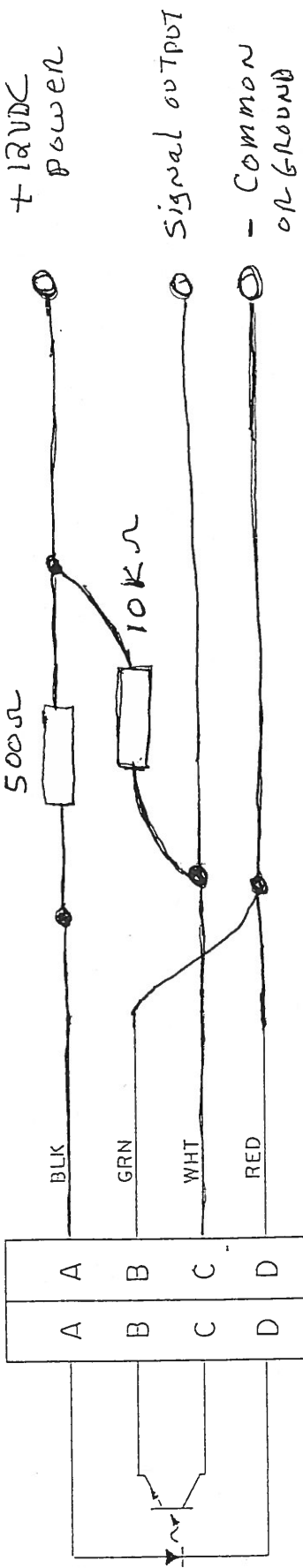

Typical  
 Signal output



06/09/98 35  
4.28.3

\*\* QUALIMETRICS, INC. \*\*  
BILL OF MATERIAL INQUIRY - 2030

06/09/98 PAGE 1  
8:29 AM (R070IZ)

LINE NO	RUN/SET UP	COMPONENT	QTY EACH	UOM
10		ECN ENGR CHANGE NUMBER ECN @ 4738, LAST CHG AS OF 5SEPT97	.0000	EA
20		2030-001 MANUAL USERS 2030	1.0000	EA
40		T800303 CUP ASSY ANEMOMETER IT-18	1.0000	EA
60		M025057 BEARING .125 X .375D IT-2	2.0000	EA
70		T711311 RING RTNG .125 EXT E IT-3	2.0000	EA
80		T712507 O-RING .070 X 1.864ID NEOPRENE IT-4	1.0000	EA
90		T712508 O-RING .070 X .551ID NEOPRENE IT-5	1.0000	EA
100		T721000 SCR 4-40 X .375 FIL SS IT-6	4.0000	EA
110		T721010 SCR 6-32 X .500 FIL SS IT-7	3.0000	EA
130		T721880 SCR 10-32 X .625 SOC SS IT-9	1.0000	EA
140		T723410 WASHER LOCK #4 SS SPLIT IT-10	4.0000	EA
150		T724000 PIN DOWEL .156 X.500 SS IT-11	1.0000	EA
160		T800200 BODY UPPER PER DRAWING IT-12	1.0000	EA

(PART NO)=A4\$ OR A4\$(1,3)="ALL"

06/09/98 35  
4.28.3

\*\* QUALIMETRICS, INC. \*\*  
BILL OF MATERIAL INQUIRY - 2030

06/09/98 PAGE 2  
8:29 AM (R070IZ)

LINE NO	RUN/SET UP	COMPONENT	QTY EACH	UOM
170		T800201 BODY LOWER PER DRAWING IT-13	1.0000	EA
180		T801600 PHOTON CHOP REC ASSY IT-14	1.0000	EA
210		M009090 WASHER FLAT #5 SS .250D .01T IT-17	2.0000	EA
220		T430043 SERIAL TAG 0.5X1.7 QUALIMETRI IT-19	1.0000	EA
230		T430044 LABEL MADE IN USA IT-20	1.0000	EA
240		M104851 WHEEL LIGHT CHOPPER W/O HUB IT-16	1.0000	EA
250		M009529 NUT HEX 6-32 SS .31HX .11TK IT-8	2.0000	EA
260		M104855 SHAFT ANEMOMETER IT-15	1.0000	EA
270		M909327 LABEL CE MARK .5" BLK ON SVR IT-21	1.0000	EA
9020	.4000 .1000	MECHANICAL ASSEMBLY	4.0000	EA
9030	.1500 .1000	TEST	4.0000	