

230-61402 Barometric Pressure Sensors

The **230-61402 Series Barometric Pressure Sensors** offer unparalleled performance and flexibility for atmospheric pressure measurement. They combine high accuracy and low power over a wide range of pressures and temperatures.

The **230-61402 BP Sensor with back plate** can be mounted in a NovaLynx data logger enclosure or protected in a weathertight polycarbonate enclosure.



BP Sensor with Back Plate

230-61402V

- Calibrated 0-5 VDC analog output (Jumper selectable 0-2.5 VDC)
- Analog current consumption is less than 4 mA. A special “sleep” mode further reduces current draw to a few μ A.
- RS232 serial output included

230-61402L

- Standard 4-20 mA output (Programmable 0-20 mA)
- User selectable serial interfaces SDI-12, RS-232, RS-485



BP Sensor with Enclosure & Pressure Port

230-61002 Pressure Port Accessory

Measurement performance of remote barometers can be seriously impaired by the effects of wind at the barometer inlet. Ambient wind of 20 meters/second blowing over a typical barometer inlet tube can cause dynamic pressure errors as high as 3 mbar. These errors can make atmospheric pressure data useless for research and forecast purposes. The 230-61002 Pressure Port reduces dynamic pressure errors to a minimum.

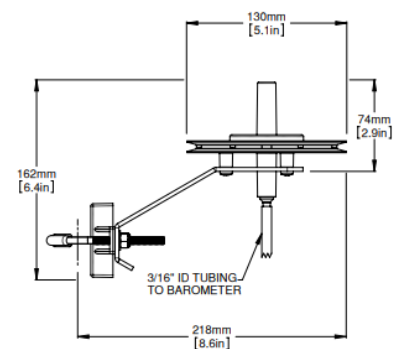

230-61002 Pressure Port

Ordering Information

- 230-61402V Barometric Pressure Sensor, 0-5V output
- 230-61402L Barometric Pressure Sensor, 4-20mA output
- 230-61360 Weatherproof Enclosure
- 230-61002 Pressure Port with Bracket
- 230-18446 Cable, 5-conductor, 22 AWG, shielded, per foot

Digital Accuracy*	0.2 hPa (25°C) 0.3 hPa (-40°C to +60°C)
Analog Accuracy**	0.05% of analog pressure range
Analog Temperature Dependence	0.0017% of analog pressure range per °C (25°C reference)
Long Term Stability	0.08% FS per year
Update Rate	2 Hz (max) to 1 per minute
Serial Output	Full duplex RS-232 SDI-12, half duplex RS-485 (230-61402L versions only) 1200, 4800, 9600, 19200, 38400 Polled or continuous ASCII text, NMEA
Analog Output 230-61402V 230-61402L	12-bit resolution (1 in 4000) Jumper selectable: 0 to 2500 mV or 0 to 5000 mV (standard) Programmable: 0 to 20 mA or 4 to 20 mA (standard)
Analog Output Scaling	500 to 1100 hPa (standard) Span may be set to any portion of the operating pressure range
Power Supply	7 to 30 VDC
230-61402V	3.6 mA with Vout (standard) 2.7 uA shutdown (Trig=0V) 7.6 mA (RS-232)
230-61402L	25 mA max (4-20 or 0-20 mA mode) 1.5 mA max in SDI-12 mode 8.5 mA (RS-232 or RS-485)
Sensor with back plate	Fiber-reinforced thermoplastic 3.5" L x 2.4" W x 0.8" D (90 x 60 x 20 mm) 1.5 oz (44 g)
Enclosure	Weatherproof

* Defined as ± 1 standard deviation from NIST-traceable pressure reference in clean, dry air. Includes non-linearity, hysteresis, repeatability, and calibration uncertainty.

** Defined as ± 1 standard deviation from ideal analog output. Total analog output accuracy is the root sum square of digital accuracy, analog accuracy, and analog temperature dependence.