

210-501

User Manual

Temperature Transmitter

with

Solar Radiation Shield



Phone (530) 823-7185

Email nova@novalynx.com Website www.novalynx.com

Receiving and Unpacking

Carefully unpack all components and compare to the packing list. Notify NovaLynx Corporation immediately concerning any discrepancy. Inspect equipment to detect any damage that may have occurred during shipment. In the event of damage, any claim for loss must be filed immediately with the carrier by the consignee. Damages to equipment sent via Parcel Post or UPS require the consignee to contact NovaLynx Corporation for instructions.

Returns

If equipment is to be returned to the factory for any reason, call NovaLynx between 8:00 a.m. and 4:00 p.m. Pacific Time to request a Return Authorization Number (RA#). Include with the returned equipment a description of the problem and the name, address, and daytime phone number of the sender. Carefully pack the equipment to prevent damage or additional damage during the return shipment. Call NovaLynx for packing instructions in the case of delicate or sensitive items. If packing facilities are not available take the equipment to the nearest Post Office, UPS, or other freight service and obtain assistance with the packaging. Please write the RA# on the outside of the box.

Warranty

NovaLynx Corporation warrants that its products are free from defects in material and workmanship under normal use and service for a period of one year from the date of shipment from the factory. NovaLynx Corporation's obligations under this warranty are limited to, at NovaLynx's option: (i) replacing; or (ii) repairing; any product determined to be defective. In no case shall NovaLynx Corporation's liability exceed product's original purchase price. This warranty does not apply to any equipment that has been repaired or altered, except by NovaLynx Corporation, or that has been subjected to misuse, negligence, or accident. It is expressly agreed that this warranty will be in lieu of all warranties of fitness and in lieu of the warranty of merchantability.

Address

NovaLynx Corporation
431 Crown Point Circle, Suite 120
Grass Valley, CA 95945-9531 USA
Phone: (530) 823-7185
Email: nova@novalynx.com
Website: www.novalynx.com

Copyright © 1988-2021 by NovaLynx Corporation

CONTENTS

1	FORWARD	4
2	INTRODUCTION	4
3	TECHNICAL SPECIFICATION	4
4	INSTALLATION	5
5	WIRING DIAGRAM.....	5
6	CALIBRATION.....	6
7	MAINTENANCE.....	6

1 FORWARD

Thank you for purchasing NovaLynx products. NovaLynx has been designing and manufacturing weather instruments since 1988. NovaLynx represents several well-known brands of quality manufacturers, including Gill Instruments, RM Young, Kipp & Zonen, and Vaisala. It is our hope that our products will meet all your monitoring requirements.

2 INTRODUCTION

The **210-501 Temperature Transmitter with Solar Radiation Shield** monitors outside air temperature using a platinum RTD sensor enclosed in a 6-plate radiation shield. The output of the RTD sensor is converted to a 4-20 mA signal calibrated from -40 to 140°F (-40 to 60°C).

The sensor can be operated as a loop-driven device or connected in 3-wire configuration. With the addition of a precision 250 ohm resistor (not supplied) the signal can be converted to a 1 to 5 Vdc signal if needed.

The mounting bracket accommodates up to 2" (5 cm) diameter masts. Standard cable length is 25 feet (7.6 m).

3 TECHNICAL SPECIFICATION

Temperature Sensor Specification	
Sensor type	Pt1000 RTD
Range / operating temperature	-40 to 140°F (-40 to 60°C)
Accuracy	±0.5°C @ 25°C
Response time	100 mS
Materials	304 stainless steel (probe), polycarbonate (housing)
Electrical connection	Terminal block (internal), tinned leads (cable)
Power	12 to 36 Vdc
Output signal	4-20 mA loop or 3-wire configuration
Cable	3 conductor 24 AWG, 25' (7.6 m) standard
Additional cable	Specify at time of order, up to 500 feet (152 m)
Enclosure rating	NEMA-4X (IP66)
Dimensions	9.5 x 5.1 x 8.3 inches (24 x 13 x 21 cm)
Weight / Shipping	1 lbs 7.4 oz (0.66 kg) / 3 lbs (1.4 kg)

4 INSTALLATION

The 210-501 Temperature Transmitter is supplied with a self-aspirated radiation shield and mast mounting hardware. Mast-mounted sensors are usually positioned at "shelter" height, or about four feet above ground level, on the north side of the mast. Temperature readings can be affected by heat reflected from the ground so try to avoid installation over asphalt or bare ground.

After mounting the sensor, route the cable to the monitoring equipment and use cable-ties to secure the cable to the mast.

5 WIRING DIAGRAM

CAUTION: Verify that power to the monitoring equipment is turned off before connecting this sensor. Failure to turn off the power may result in a short circuit that could cause permanent damage to your equipment. Refer to the wire diagrams below for 2-wire and 3-wire connections.

210-501 Temperature Transmitter Wiring Diagram

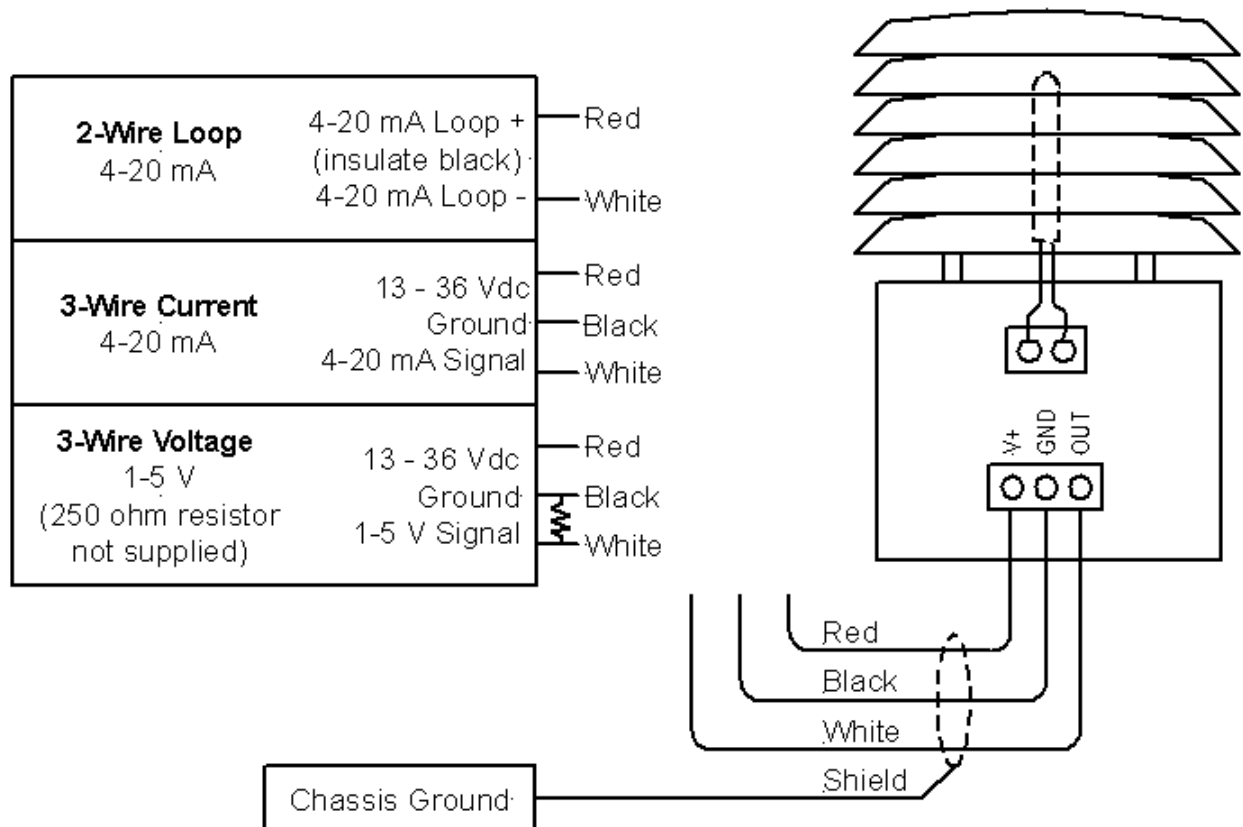

6 CALIBRATION

The 210-501 Temperature Transmitter is factory calibrated and does not require field adjustment. If the readings from this sensor are not within specification, please ensure the monitoring equipment is functioning correctly and all wiring has been inspected. If the problem cannot be located contact NovaLynx for repair or warranty service if required.

7 MAINTENANCE

The 210-501 Temperature Transmitter with Solar Radiation Shield require little maintenance. A periodic visual inspection of the wiring and housing to ensure both are in good condition is usually sufficient. The louvers of the radiation shield can be cleaned with water or dilute detergent solution if required.

If the unit has been subjected to severe wind and rain it may be necessary to remove the front cover to inspect for water entry. Loosen the four screws in the corners of the lid with a large-blade screwdriver. Allow the chassis to dry thoroughly before re-installing the cover.

