

# NOVALYNX CORPORATION

MODEL 230-7020-A  
BAROGRAPH

INSTRUCTION MANUAL

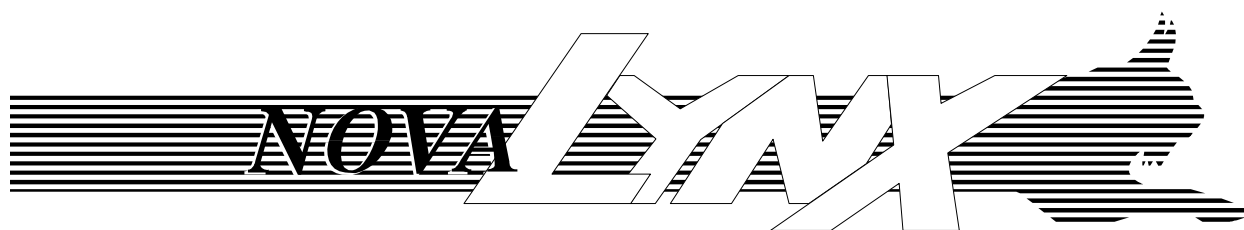

REVISION DATE: OCT 1996

## Receiving and Unpacking

Carefully unpack all components and compare to the packing list. Notify NovaLynx Corporation immediately concerning any discrepancy. Inspect equipment to detect any damage that may have occurred during shipment. In the event of damage, any claim for loss must be filed immediately with the carrier by the consignee. Damages to equipment sent via Parcel Post or UPS require the consignee to contact NovaLynx Corporation for instructions.

## Returns

If equipment is to be returned to the factory for any reason, call NovaLynx between 8:00 a.m. and 4:00 p.m. Pacific Time to request a Return Authorization Number (RA#). Include with the returned equipment a description of the problem and the name, address, and daytime phone number of the sender. Carefully pack the equipment to prevent damage or additional damage during the return shipment. Call NovaLynx for packing instructions in the case of delicate or sensitive items. If packing facilities are not available take the equipment to the nearest Post Office, UPS, or other freight service and obtain assistance with the packaging. Please write the RA# on the outside of the box.

## Warranty

NovaLynx Corporation warrants that its products are free from defects in material and workmanship under normal use and service for a period of one year from the date of shipment from the factory. NovaLynx Corporation's obligations under this warranty are limited to, at NovaLynx's option: (i) replacing; or (ii) repairing; any product determined to be defective. In no case shall NovaLynx Corporation's liability exceed product's original purchase price. This warranty does not apply to any equipment that has been repaired or altered, except by NovaLynx Corporation, or that has been subjected to misuse, negligence, or accident. It is expressly agreed that this warranty will be in lieu of all warranties of fitness and in lieu of the warranty of merchantability.

## Address

**NovaLynx Corporation**  
**4055 Grass Valley Highway, Suite 102**  
**Auburn, CA 95602**  
**Phone: (530) 823-7185**  
**Fax: (530) 823-8997**  
**Email: [nova@novalynx.com](mailto:nova@novalynx.com)**  
**Website: [www.novalynx.com](http://www.novalynx.com)**

Copyright © 1996 by NovaLynx Corporation

# TABLE OF CONTENTS

Section No.	Page No.
1.0 INTRODUCTION .....	1
2.0 SPECIFICATIONS .....	2
3.0 INSTALLATION .....	3
3.1 GENERAL UNPACKING .....	3
3.2 INSTRUMENT UNPACKING .....	3
3.3 ANEROID CELL ATTACHMENT .....	4
3.4 CLOCK UNPACKING .....	4
3.5 CHART PAPER INSTALLATION .....	5
3.6 CLOCK INSTALLATION .....	6
4.0 OPERATION .....	7
4.1 BAROGRAPH .....	7
4.2 BIMETAL STRIP .....	8
4.3 DRUM RECORDER .....	8
5.0 CALIBRATION .....	8
6.0 MAINTENANCE .....	9
7.0 LIST OF CHART PAPER .....	10



# NovaLynx Corporation

## Model 230-7020-A Barograph Instruction Manual

### 1.0 INTRODUCTION

NovaLynx Corporation is a distributor of the Model 230-7020-A Barograph. A barograph provides a written record of barometric or atmospheric pressure and is designed for professional meteorological and industrial uses. The barograph has been designed to operate from sea level up to an elevation of 12,000 feet.

The Model 230-7020-A uses an evacuated, metal bellows, called an aneroid cell, for sensing the changes in the atmospheric pressure. Mechanical linkages from the aneroid cell cause a pen arm to move creating a recording of the pressure changes onto a rotating drum chart. The recording chart is a removable paper sheet. Each chart is placed onto a rotating drum that driven by a precision electronic clock. The clock is powered by two AA size alkaline batteries. The barograph housing and instrument components have been designed for use in outdoor areas with some protection. Whenever the barograph is to be used to measure outdoor atmospheric conditions, it should be located inside an instrument shelter such as the Cotton Region style shelter, Model 380-605. Exposure to direct sunlight and excessive heat will cause data errors.

Earlier versions of the Model 230-7020-A Barograph had several model numbers to cover several different types of clocks and the chart paper used with the clocks. These earlier clocks were both spring wound and electric, with daily, weekly and monthly drive mechanisms. The current style of barograph supplied by NovaLynx has a single model number, 230-7020-A, and is distinguished by the electronic clock inside the drum recorder. The electronic clock is quartz crystal driven and includes a selector switch allowing the user to switch the clock rotation from one day (26 hours), to seven days (176 hours), or to 31 days. Additional time is provided on the clock rotation and on the chart paper to allow overlap of data in case the chart is not replaced within the normal time period. The three different timing settings on the clock requires a number of different chart papers to cover both the time settings and the range of pressures. A list of available chart paper by model numbers is provided at the end of this manual.

The electronic clock eliminates the need to change drive gears whenever the chart paper time base is changed. In earlier models the changing of the clock drive gears was critical and if not changed properly resulted in lost data and sometimes in damaged clocks. The need to store and to keep track of the different drive gears has been eliminated by the electronic clock.

The chart paper used on the drum recorder uses a single recording sections. The chart has the zero or low-scale at the bottom edge of the paper and the full or high-scale at the upper edge of the chart. The chart paper wraps around the drum of the clock and is marked by a disposable cartridge ink pen. The barometric pressure range of the chart

paper and the time base are selected at the time of purchase. Additional packs of the same chart paper or chart paper with a different range or a different time base may be ordered at any time from NovaLynx. Some customers may find that charts with a different pressure range or a different time base is required during different times of the year depending upon seasonal variations and the use of the recorded information. More than a single recording site may be required in some instances. The chart paper has a location at the end margin for the station identification and the date. The starting date of the chart or the ending date or both may be recorded on the chart.

A properly maintained instrument will provide many years of useful service. Refer to the maintenance section of this manual for information regarding the care of the instrument. Contact NovaLynx for additional assistance or for repairs and replacement parts.

## 2.0 SPECIFICATIONS

Sensor:	Sealed Aneroid Bellows 14 cells, 2 1/4" diameter
Temperature Compensation:	Aged Bimetal Strip
Accuracy:	± 0.2%
Recording Range:	27.9 to 31.0 inHg 945 to 1045 mb
Resolution:	0.01 inHg 0.25 mb
Chart Graduations:	0.05 inHg 2.5 mb
Operating Range:	Sea Level to +12000 feet
Recording Method:	Cartridge Ink Pen
CLOCK	
Type:	Precision Electronic Drive
Power:	3.0 VDC, 2 each AA batteries
Rotation:	26 Hours, 176 Hours, 31 Days, Selectable
Case Size:	13 x 9.5 x 6 inches (l x h x w) 330 x 241 x 152 mm
Weight:	9 lbs (4 kg)
Shipping Weight:	15 lbs (7 kg)

## **3.0 INSTALLATION**

### **3.1 GENERAL UNPACKING**

Typically, NovaLynx will ship the barograph in two cartons; an inner carton and an outer carton. The two cartons provide maximum protection of the instrument during shipping. In the case where there are more than one instruments being shipped, there will be several instruments packed into the outer carton.

Before opening the outer carton or immediately after opening, inspect the two cartons for signs of shipping damage: holes in the carton, dented or crushed corners and sides. Report any signs of damage to the carrier, preferably before he leaves the area. There may be unseen damage to the instrument that may not become visible until everything has been unpacked and closely inspected. Any claims against damaged equipment must be made immediately to the carrier. NovaLynx may be able to assist the customer in handling damaged equipment, however it is the responsibility of the receiver of the goods to take care of any problems caused by the carrier. Refer to page i.

The inside carton containing the barograph has been customized with styrofoam inserts to provide maximum protection for the instrument. Save the inside carton and the styrofoam inserts for use in reshipment of the instrument or for long term storage.

Lifting off the top section of styrofoam will expose the clock and the instrument case. Carefully remove both items and place them onto a flat surface. Close up the carton and store it away.

### **3.2 INSTRUMENT UNPACKING**

Open the barograph case by pressing the release button on the end of the case and at the same time lifting gently upward on the handle located on the top of the case. The top of the case will swing upward and to the side away from the latch. The latch release button is on the end opposite the case window. With the window facing toward the operator, the latch should be on the left side and the sensor on the right side.

With the case open notice that the pen arm is fastened to the upright bar by a small clip. The clip keeps the pen arm from moving during shipping and must be removed for the pen to move freely on the chart. Press inward on the curved piece of the clip to open it. Slide the clip upward. Rotate the edge of the pen arm into the open part of the clip. Slide the clip downward past the pen arm. The clip may be left on the lifter bar or it can be taken off and stored inside the shipping carton. Notice that the pen lifter bar has a knob that can be rotated. The bar is used to lower the pen onto and to lift the pen off the chart paper to help avoid smears and extraneous marks on the chart.

Several pieces of packing material may be located around the edges of the instrument case. These pieces will fall out or become loose as the case is opened. Remove these pieces of packing and store them with the shipping carton.

### **3.3 ANEROID CELL ATTACHMENT**

The barograph is shipped with the aneroid cell disconnected from the pen arm linkages. This is done to prevent damage to the mechanisms in case the instrument is shipped in unpressurized containers and at altitudes above 12,000 ft. To attach the aneroid cell to the pen arm linkages, first locate the keeper pin. The keeper pin is a small cotter pin and it is usually taped onto the instrument case near the base of the aneroid cell. Locate the lever arm attached to the top of the aneroid cell. Rotate the lever arm until its end is inside the slot of the linkage bar located directly above the aneroid cell. Notice that the linkage bar also has a small hole on the side for the keeper pin. Align the lever arm hole with the hole in the linkage bar and slide the keeper pin through the hole, connecting both parts together. Bend the end of the keeper pin slightly where it exits the other side of the linkage bar to prevent it from falling out. Check the assembly by lightly pressing on the aneroid cell to see that the pen arm moves.

The span of the barograph has been set at NovaLynx for a 100 mb range. The only operational adjustment necessary is for altitude compensation. Loosen the knurled screw located on the side of the altitude adjustment assembly. Rotate the knurled nut located on top of the assembly to obtain the correct barometric pressure reading. The correct local reading may be obtained from a nearby airport or from a weather forecast center. Use the knurled screw on the pen arm assembly to make fine adjustments. Check to be sure that the knurled screw on the altitude adjustment assembly has been tightened after all adjustments have been completed.

### **3.4 CLOCK UNPACKING**

The clock is generally shipped wrapped inside a plastic bag. Remove the clock from the bag. A nickel plated chart clip should be installed along one side of the drum. If the clip is not on the clock search the carton in case it may have become loose during shipping or was placed into the carton separately. If there is no chart clip notify NovaLynx immediately. If the clip is on the clock, slide it upward and remove it from the drum. If the main shaft has been shipped installed inside the clock and not on the base of the instrument, remove the shaft from the clock and install it onto the base. The shaft is removed from the clock by loosening and removing the brass thumb nut inside the top of the clock drum. Slide the shaft down and out of the clock. Place the shaft onto the base. Be sure to put the aluminum spacer between the large gear and the base of the instrument. Below the case, install the lock washer and the two hex nuts. Tighten the hex nuts so that the shaft will not rotate or wobble.

Open the clock drum by grasping the bottom of the clock with one hand and the brass drum with the other hand. Be careful. There may be sharp edges that can cut. Look closely at the bottom edge of the clock drum. There should be three small pins that hold the drum onto the bottom plate. Notice the position of the slot around the pins. Rotate the two clock pieces in opposite directions to separate them. The rotation of the top of the clock will be in the direction required to move the pin in the slot. Typically, the clock drum will be rotated in a counter-clock-wise direction while the bottom plate rotates clock-wise to separate the two sections of the clock assembly.



With the brass drum removed from the clock, the battery holder will be exposed. Insert the two AA sized batteries into the battery holders. Batteries are not normally supplied with the instrument by NovaLynx due to lower prices and better availability from local sources. In special situations and when requested, batteries may be supplied by NovaLynx. Notice the polarity markings on the plastic battery holders. Check to be sure that the batteries face correctly as they are being inserted. Also notice that the batteries are wired in series to produce the 3.0 volts needed to operate the clock.

Upon completion of the battery installation, look at the top of the clock assembly. One of the three LEDs should be flashing to indicate that it is operating. If no LED is flashing check the batteries to make certain that they have power and check to see that the batteries are facing correctly in the holders. If the clock does not appear to be working contact NovaLynx for assistance.

If the LED is flashing and the clock appears to be working properly, replace the clock drum onto the bottom plate. Notice that the chart clip notch in the drum must be in line with the slot in the bottom plate when the clock is put back together. Rotate the two pieces together until the pins are against the front edges of the slots.

### **3.5 CHART PAPER INSTALLATION**

The chart paper used with the drum recorder is installed easiest with the clock removed from the instrument. To install the chart paper, first remove the chart clip from the clock drum. Select the chart paper that is to be installed onto the drum. Check to see that the blank lines for the station ID number and the start date of the chart have been filled in if required. If the chart information has been written onto the end of the chart, fold down the end margin exactly along the end line of the calibrated portion of the chart. The fold will place the station ID and the date under the chart.

Slide the chart clip in between the folded portion of the chart. The edge of the clip must sit in the crease of the fold. Hold this end of the chart in one hand. With the other hand, take the left hand edge of the chart paper and wrap it around the clock drum. The paper should be positioned so that the end of the chart will line up with and overlap slightly the chart clip slot located on the bottom plate of the clock.

Holding the end of the chart paper against the drum, slide the chart clip into the slot on the bottom plate and insert the top of the clip into the notch on the upper edge of the drum. Notice that when inserting the chart clip, the edge of the chart with the clip will overlap the end of the chart being held against the drum. Press firmly on the free end of the chart to prevent it from slipping out as the chart clip is put into place. Several attempts at loading the chart paper may be necessary until familiarity with the procedure has been attained.

A properly loaded chart paper will be tightly wrapped around the drum of the clock. The folded edge of the paper will be seated against the chart clip. The free end of the paper will be underneath the chart clip and aligned with the overlapping portion of the chart paper. If the chart paper slips or moves during the insertion of the chart clip, it may be

necessary to start over in order to properly align the edges of the chart. The bottom edge of the chart paper with the zero side of the scale, must be touching the bottom plate of the clock.

With the chart paper properly installed, the ink pen will be able to write on all of the chart and will travel easily over the chart on top of the chart clip.

### **3.6 CLOCK INSTALLATION**

Next, the clock is placed onto the shaft that has been installed into the case of the barograph. First, the brass nut at the top of the shaft must be removed. Place it to one side since it must be used to fasten the clock in place. There is a spacer located between the shaft and the case. The spacer must be in place and the shaft must be securely fastened to the case in order for the clock to properly operate. If the spacer appears to be missing notify NovaLynx for a replacement. Check the shaft to make certain that it does not rotate or move. If it appears to be loose, tighten the nuts located underneath the instrument case. If everything appears to be correctly placed, position the clock over the shaft and secure it to the shaft on the top side using the brass thumb nut. Do not over-tighten the brass nut. Finger-tight should provide plenty of force to keep the clock on the shaft. The clock should rotate freely around the shaft.

Check at this point to ensure that the pen is lifted away from the chart paper surface. To begin recording data, rotate the clock in a clock-wise direction until the correct time line appears beneath the pen tip. For weekly and monthly charts check to ensure that the day of the week has also been correctly selected.

Before placing the pen onto the chart notice that each pen has a protective cap (usually White) covering the tip of the pen. Remove the cap to expose the fiber tip of the pen. Save the cap and use it to cover the pen whenever it is not being used in order to extend the pen's life.

Lower the pen onto the chart paper by rotating the pen lifter bar. Move the pen gently up and down a small distance to make an arc on the chart paper. Look at the mark to see whether it has written on top of the timing mark. If necessary move the clock to correct the position until the pen is at the timing mark. Rotate the clock only in a clock-wise direction. Due to back lash in the clock gear mechanism there will be some loss of time if the clock is moved in a counter-clock-wise direction. The clock will not move until the back lash slack is recovered.

The barograph is shipped with the aneroid cell disconnected from the pen arm linkages. This is done to prevent damage to the mechanisms in case the instrument is shipped in unpressurized containers and at altitudes above 12,000 ft. To attach the aneroid cell to the pen arm linkages, first locate the keeper pin. The keeper pin is a small cotter pin and it is usually taped onto the instrument case near the base of the aneroid cell. Locate the lever arm attached to the top of the aneroid cell. Rotate the lever arm until its end is inside the slot of the linkage bar located directly above the aneroid cell. Notice that the linkage bar also has a small hole on the side for the keeper pin. Align the lever

arm hole with the hole in the linkage bar and slide the keeper pin through the hole connecting both parts together. Bend the end of the keeper pin slightly where it exits the other side of the linkage bar to prevent it from falling out. Check the assembly by lightly pressing on the aneroid cell to see that the pen arm moves.

The span of the barograph has been set at NovaLynx for a 100 mb range. The only operational adjustment necessary is for altitude compensation. Loosen the knurled screw located on the side of the altitude adjustment assembly. Rotate the knurled nut located on top of the assembly to obtain the correct barometric pressure reading. The correct local reading may be obtained from a nearby airport or from a weather forecast center. Use the knurled screw on the pen arm assembly to make fine adjustments. Check to be sure that the knurled screw on the altitude adjustment assembly has been tightened after all adjustments have been completed.

After the initial set-up of the barograph, let the instrument operate for a period of time to ensure that the clock is operating properly and that the pen is writing on the chart paper. Notice that for weekly and monthly charts, the clock rotation will be very slow and that it will take at least one or two days to check the clock rotation. Try to perform the clock operation test before permanently installing the instrument to avoid the loss of critical data. During the clock operation test, also check the local barometric pressure to ensure that the instrument is measuring correctly. If the calibration needs adjusting refer to the steps for making those adjustments.

Final installation of the barograph involves placing the instrument into an instrument shelter for outdoor locations or onto a shelf or table top for indoor locations. The instrument should be as level as possible. In locations where there may be dripping water, place a protective panel above the instrument to prevent water from dropping directly onto or near the instrument case. Water should not splash onto the sensor or the chart paper. Avoid placing the instrument into a location where there may be direct exposure to sunlight.

## **4.0 OPERATION**

### **4.1 BAROGRAPH**

The barograph measures atmospheric pressure changes through the use of a multiple cell aneroid bellows that has been completely evacuated of air and then sealed. One end of the bellows is attached to a mechanical linkage to drive the pen. The other end of the aneroid bellows is attached to the instrument case. Atmospheric pressure changes cause the aneroid bellows to expand and contract. These expansions and contractions are transmitted to the pen through the mechanical linkage. The pen arm motion causes the pen tip leave an ink trace on the chart paper. The chart paper rotates past the pen tip providing a smooth trace that shows the pressure change with time.

A one hundred millibar span can be adjusted upward or downward allowing the instrument to cover different altitudes. The altitude adjustment is provided using the knurled knob attached to the altitude adjustment assembly. Slight corrections in pressure readings are accomplished using the knurled screw located on the pen arm.

## **4.2 BIMETAL STRIP**

A bimetal strip located between the pen arm and the aneroid bellows provides temperature compensation to eliminate fluctuations in the readings due to ambient temperature variations.

## **4.3 DRUM RECORDER**

The barometric pressure data is recorded onto a calibrated paper chart. The physical changes of the aneroid cell is translated into upward and downward motion of the pen arm. As the pen arm moves, an ink trace of the movement is made on the chart paper. The chart paper moves beneath the pen by the battery powered clock mechanism of the drum recorder.

The clock mechanism is driven by a precision, crystal controlled, electronic clock. The clock produces pulses that are translated into movement through an electric motor. The motor in turn drives the gears of the clock producing the rotation of the drum and chart paper. The drum and clock are fastened onto a fixed shaft and rotate around the shaft. The clock rotation period is selected through the slide switch located on top of the clock assembly and can be set to 1 day, 7 days, or 31 days. The settings are imprinted into the switch. A flashing LED sits above each switch position to indicate that the clock is operating and to show which time period has been selected.

## **5.0 CALIBRATION**

5.1 Calibration of the barograph requires precision and experience. Only qualified instrument technicians familiar with barometers should attempt to adjust the instrument. For assistance please contact NovaLynx.

5.2 Place the instrument case into a pressure/temperature test chamber. Maintain a constant pressure and vary the temperature. Loosen the small screw on the bimetal strip and adjust the slide assembly until the changes due to temperature fluctuations do not affect the barometric pressure readings.

5.3 Span adjustments are made by using the following procedure.

Place the instrument into a pressure test chamber.

Bring the pressure down until a reading that is close to the bottom of the chart, zero-scale, is reached.

Record the reading.

Change the chamber pressure to get a reading at or near the full-scale edge of the chart.

NOTE: If an error in the span is evident adjust the pen linkage at the pen pivot shaft. Shorten the pivot shaft to increase pen travel; lengthen to decrease pen travel. Make a small adjustment and retest. Measure the shaft length after each adjustment to keep track of the change in adjustment.

Repeat procedure until readings are correct.

## **6.0 MAINTENANCE**

The barograph is typically used indoors to measure atmospheric pressure changes since there is usually little or no difference between the indoor pressure and the outdoor pressure. Instruments will tend to gather dust over time and in the case of high humidities some parts may become corroded. Instruments that are mounted in outdoor, louvered shelters will see an increase in dust and moisture problems. General maintenance is relatively simple and when performed regularly can extend the life of the instrument.

The chart paper will require changing at the time intervals that is the time base of the chart, daily, weekly or monthly. It is during the chart changing that general maintenance should be performed. Simply brush off any dust or dirt, spider webs, leaves, and any other debris that has settled onto or inside the case. If there is excessive moisture, take along some dry cloths to dry off the case. At least once every 6 months, 3 months in harsh environments, clean all pivots and bearing points with a solvent. Apply a light coating of instrument oil to the pivots and bearings. Use a small brush to apply one or two drops of the oil.

Check the clock batteries for corrosion and if possible test them for the amount of power left to help avoid battery failure between visits. If rechargeable batteries are being used, exchange the batteries on a regular basis, keeping fresh batteries in the clock whenever possible. If standard alkaline batteries are being used in the clock, they should be replaced at least every 6 months.

Be sure to brush dust and dirt off the aneroid cell and temperature compensation strip. Use a soft brush.

Pen traces will become faint as the pen cartridge approaches the end of its life. It is recommended that at least two additional pen tips be kept as spares for replacement as needed. The old pen is slid off the end of the pen arm and the new one is slid on in its place. When replacing pens grasp the pen arm without bending it and carefully but forcefully pull the old pen off and push the new pen on. If the pen arm becomes bent carefully reshape it as closely as possible to its original shape. Severely damaged pen

arms should be replaced. The pen arm is held in place by a small circular plate and two screws. The pen arm is clamped onto a small post by the plate and screws.

For locations experiencing high humidity, the chart paper can be acclimated by storing all or some of the chart paper in the shelter next to the instrument. This method of storage helps keep the chart paper from changing size rapidly after it is placed onto the clock drum. The amount of ink absorbed by the paper will also be affected since a drier chart paper will take more ink than paper that is more moist.

Drawings are provided with this manual to assist in the identification of major parts. Should a replacement part be required that is not shown in detail please contact NovaLynx for assistance or send a sketch showing the part and its general location.

## 7.0 LIST OF CHART PAPER

<b>Model #</b>	<b>Range</b>	<b>Period</b>	<b># of Sheets</b>
230-70201	945 to 1045 mb	7 days	55
230-70252	27.9 to 31.0 inHg	7 days	55
230-70208	27.9 to 31.0 inHg	7 days	55
	(No numbers printed on chart 230-70208)		
230-70253	705 to 785 mmHg	7 days	55

NOVALYNX BAROGRAPH MODEL 230-7020-A  
PARTS LIST

REF. NO.	NL PART NO.	QTY	DESCRIPTION
1	390-88101	1	PEN CARTRIDGE, BLUE
3	8828-A	1	CLOCK ASSEMBLY
6	88271	1	CHART CLIP
7	97000100	1	BASE, INSTRUMENT HOUSING
8	97000101	1	COVER, INSTRUMENT HOUSING
9	97000102	1	WINDOW, GLASS PLATE
10	97000103	1	LATCH, COVER AND BASE
11	97000104	1	PEN ARM
12	97000105	1	ANEROID CELL
13	97000106	1	ALTITUDE ADJUSTMENT KNOB
14	97000107	1	SCREW , LOCKING, KNURLED
15	97000108	1	BIMETAL STRIP, TEMP COMP
16	97000109	1	ADJUSTMENT SLIDE
17	97000110	1	SCREW, FINE ADJUSTMENT
18	97000111	1	LIFTER, PEN
19	97000112	1	SHAFT ASSEMBLY, PEN PIVOT

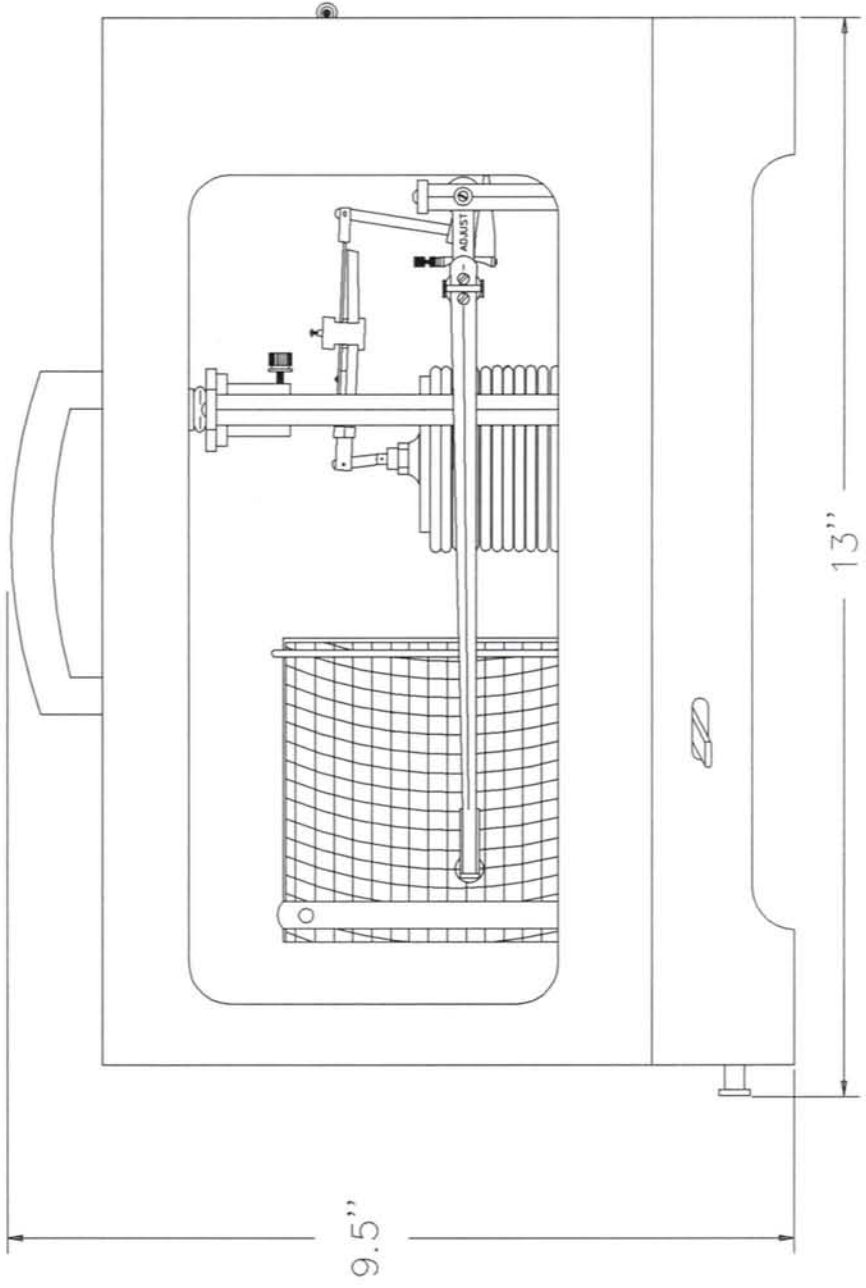

	
TITLE    OUTLINE, BAROGRAPH MODEL 230-7020-A	
MODEL USAGE 230-7020-A	SHEET 1 OF 1
BY    RGN	SCALE DWG. NO. 961029
DATE 10-23-96	FULL



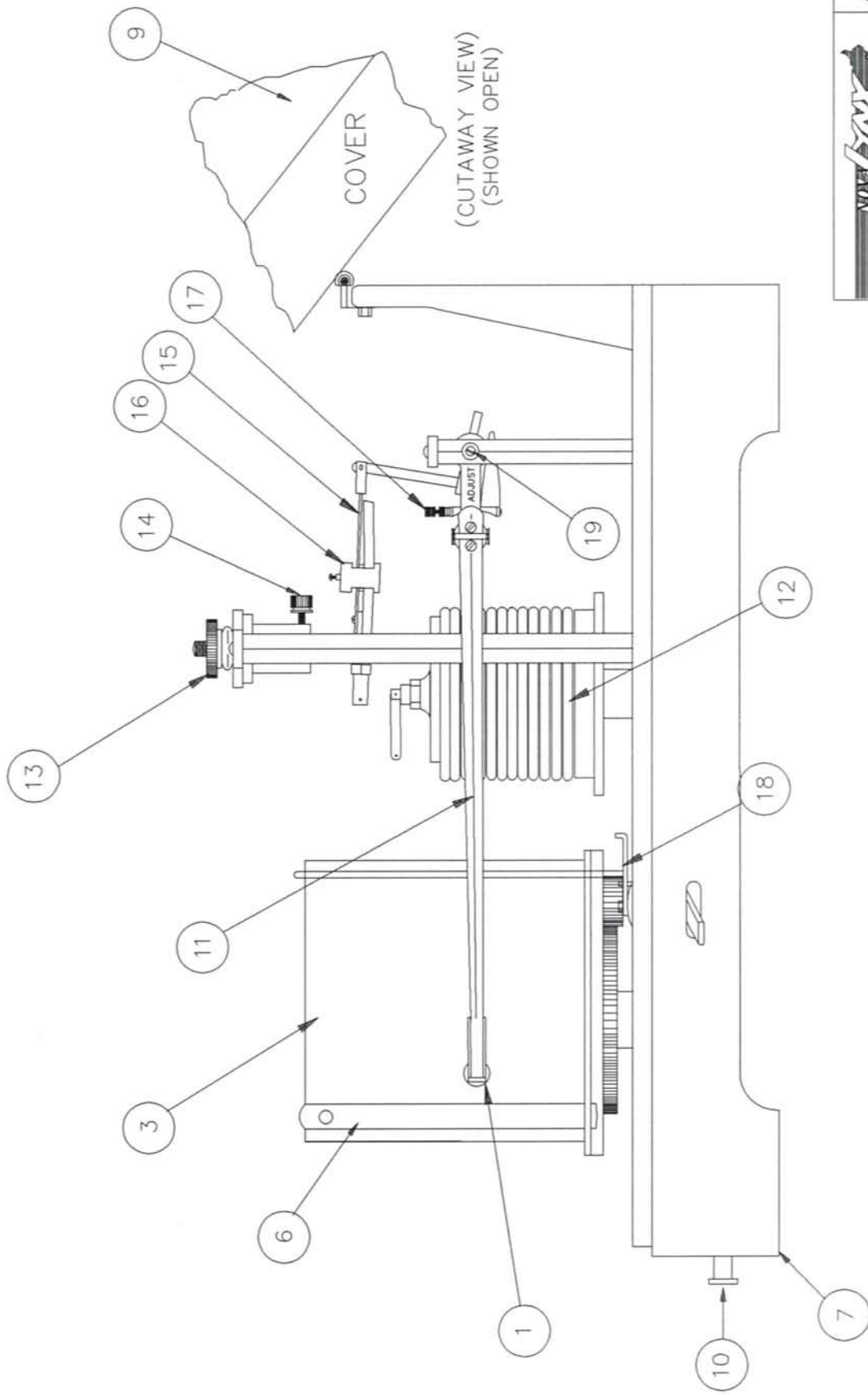

<b>NOVEX</b> CORPORATION		<b>C</b>
TITLE ASSEMBLY, BAROGRAPH MODEL 230-7020-A		
MODEL USAGE 230-7020-A		SHEET 1 OF 1
BY RGN	SCALE DWG. NO.	DATE 10-23-96
	NONE	961032

NOTES: 1. NUMBER IN BUBBLE IS PARTS LIST REF. NO.

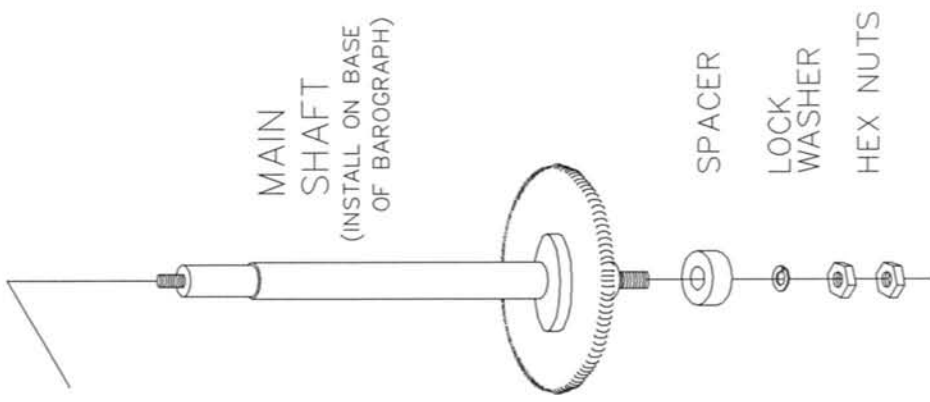

SPACER IS INSTALLED BETWEEN MAIN SHAFT & INSTRUMENT CASE.

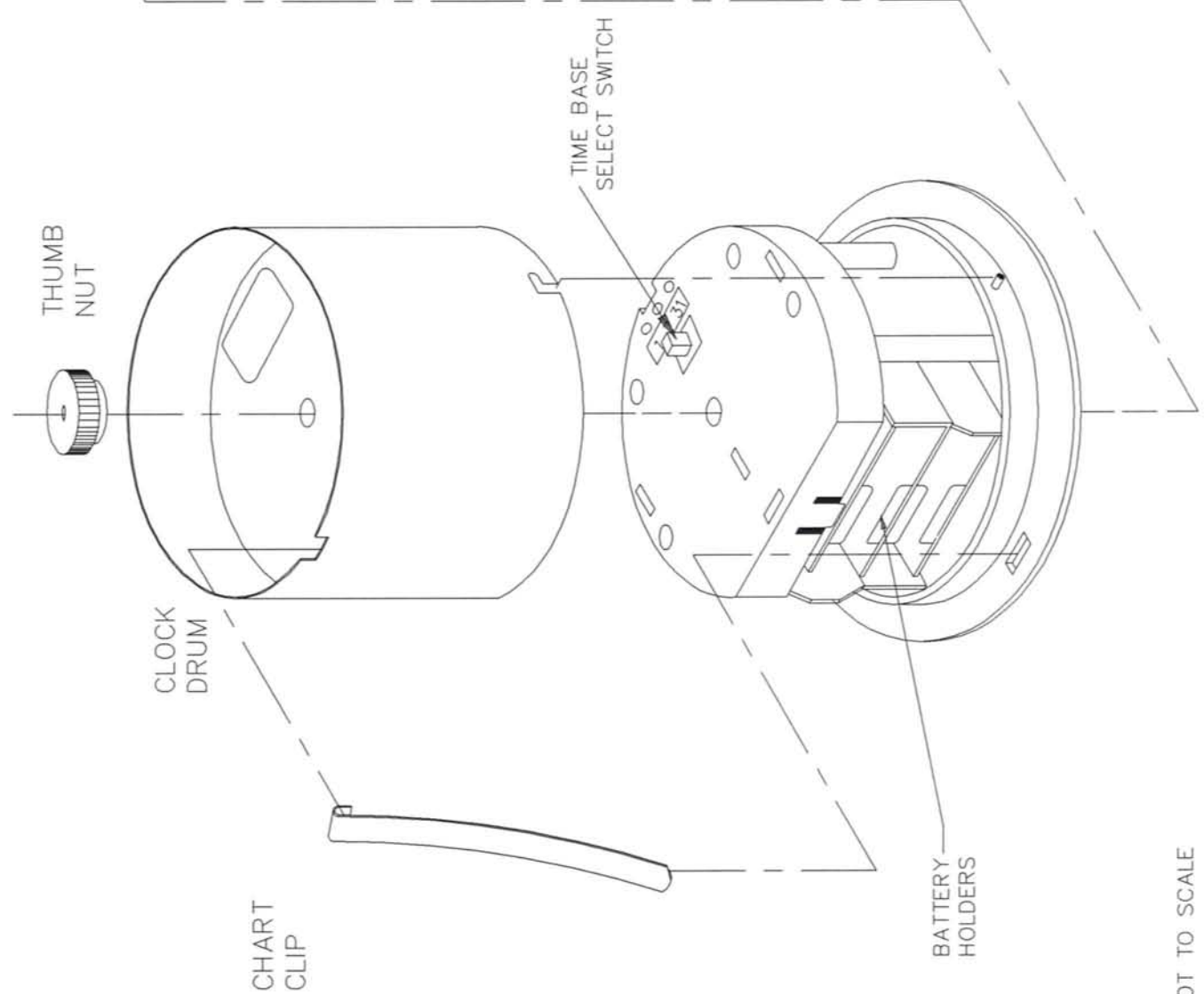

<b>TITLE</b> ASSEMBLY, ELECTRONIC CLOCK	
MODEL USAGE 230-7020-A	SHEET 1 OF 1
BY RGN	SCALE DWG. NO. 961030
DATE 10-23-96	NONE

DRAWING NOT TO SCALE

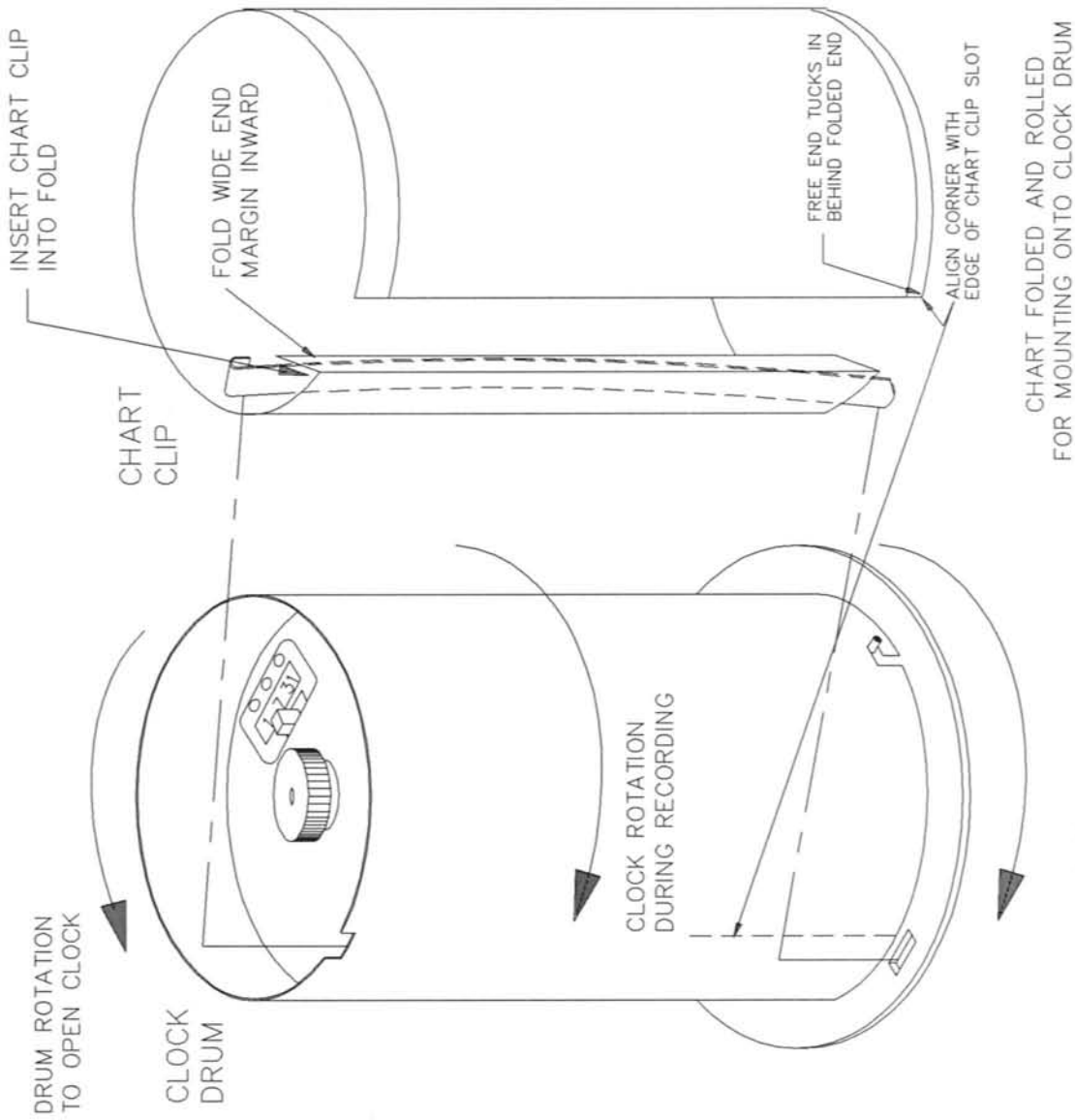

PRINTED SIDE  
FACES OUT

TITLE OUTLINE, ELECTRONIC CLOCK CHART PAPER LOADING	
MODEL USAGE 230-7020-A	SHEET 1 OF 1
BY RGN	SCALE DWG. NO. 961031
DATE 10-23-96	NONE

DRAWING NOT TO SCALE