



WindSonic

User Manual

Doc No. 1405-PS-0019

Issue 15

Gill Instruments Limited

Saltmarsh Park,
67 Gosport Street,
Lymington,
Hampshire.
SO41 9EG
UK

Tel: +44 (0) 1590 613500
Fax: +44 (0) 1590 613501
E-mail: anem@gill.co.uk
Website: www.gill.co.uk



Contents

1	FOREWORD	4
2	INTRODUCTION	4
3	FAST TRACK SET-UP	4
4	PRINCIPLE OF OPERATION	5
5	SPECIFICATION	7
6	PRE-INSTALLATION	9
6.1	EQUIPMENT SUPPLIED.....	9
6.2	PACKAGING.....	9
6.3	INSTALLATION REQUIREMENTS	10
6.4	CABLE ASSEMBLY.....	11
6.5	WINDCOM	14
7	INSTALLATION	15
7.1	INSTALLATION GUIDELINES	15
7.2	BENCH SYSTEM TEST	16
7.3	ELECTRICAL.....	16
	<i>Cable</i>	16
	<i>Power supply</i>	17
	<i>Configuring Hyperterminal</i>	18
	<i>Auto Mode</i>	18
	<i>Connecting to a PC using RS232 (Options 1, 2 or 3)</i>	19
	<i>Connecting to a Gill WindDisplay</i>	20
	<i>Connecting to a PC using RS422 (Option 2 or 3)</i>	21
	<i>Networking using RS485 (Option 2 or 3)</i>	22
	<i>Using the Analogue Output (Option 3)</i>	23
	<i>Connecting to an SDI-12 Interface (Option 4)</i>	24
7.4	MECHANICAL.....	25
	<i>Orientation</i>	25
	<i>Alignment</i>	25
	<i>Mounting</i>	25
8	USING WITH THE GILL WindDisplay	27
9	MESSAGE FORMATS	28
9.1	GILL FORMAT– POLAR, CONTINUOUS (DEFAULT FORMAT)	28
9.2	GILL FORMAT – UV, CONTINUOUS	30
9.3	GILL FORMAT – POLLED (POLAR OR UV).....	31
9.4	NMEA FORMAT	31
9.5	ANALOGUE OUTPUTS AND OPTIONS.....	32
10	CONFIGURING	34
10.1	ENTERING CONFIGURATION MODE.....	34
10.2	RETURNING TO MEASUREMENT MODE	34
10.3	CHECKING THE CONFIGURATION	34
10.4	CHANGING A SETTING.....	35
10.5	MEASUREMENT SETTINGS.....	35
10.6	OUTPUT UNITS	35

10.7	ASCII OUTPUT FORMAT	35
10.8	MESSAGE TERMINATOR.....	36
10.9	OUTPUT RATE	36
10.10	BAUD RATE	36
10.11	DATA AND PARITY OPTIONS	36
10.12	POWER-UP MESSAGE	37
10.13	NODE ADDRESS.....	37
10.14	COMMUNICATIONS PROTOCOL.....	37
10.15	ANALOGUE SETTINGS	38
	<i>Polar mode direction calculation</i>	38
	<i>Magnitude scaling</i>	38
	<i>Error conditions</i>	39
	<i>Disabled outputs</i>	39
10.16	CONFIGURATION / DIAGNOSTIC INFORMATION.....	39
11	SDI-12 COMMANDS	40
12	MAINTENANCE & FAULT-FINDING	42
12.1	CLEANING	42
12.2	SERVICING	42
12.3	FAULT FINDING	42
12.4	RETURNING UNIT	43
12.5	STATUS	43
13	TESTS	44
13.1	BENCH TEST	44
13.2	SELF-TEST (STILL AIR)	45
13.3	CALIBRATION.....	46
14	APPENDICES	47
14.1	GLOSSARY & ABBREVIATIONS	47
14.2	GUARANTEE	47
14.3	ELECTRICAL CONFORMITY	48

1 FOREWORD

Thank you for purchasing the WindSonic manufactured by Gill Instruments Ltd. The unit has no customer serviceable parts and requires no calibration or maintenance. To achieve optimum performance we recommend that you read the whole of this manual before proceeding with use. Do NOT remove black "rubber" transducer caps.

Gill products are in continuous development and therefore specifications may be subject to change and design improvements without prior notice.

The information contained in this manual remains the property of Gill Instruments and should not be copied or reproduced for commercial gain.

2 INTRODUCTION

The Gill WindSonic wind sensor is a very robust, lightweight unit with no moving parts, outputting wind speed and direction. The units of wind speed, output rate and formats are all user selectable.

The WindSonic can be used in conjunction with a PC, datalogger or other device, provided it is compatible with one of the standard communication formats provided by the WindSonic.

WindSonic (option 2 or 3 only) is designed to connect directly to the Gill WindDisplay unit to provide a complete wind speed direction system without any configuration by the user.

WindSonic (options 1, 2 and 3) may be configured using WindCom software which is available, free of charge, from the Gill website www.gill.co.uk.

WindSonic (option 4) SDI-12 may not be re-configured in any Gill output format.

The output message format can be configured in Gill format, in Polar or UV (2-axis) format, and to either Polled (requested by host system) or Continuous output. Alternatively, it can be configured in NMEA (0183 Version 3) or SDI-12 (V1.3). These are described in Section 9 MESSAGE FORMATS and Section 11 SDI-12 COMMANDS.

3 FAST TRACK SET-UP

If you are in a hurry to try out the WindSonic (options 1, 2 or 3) and are familiar with Gill equipment and coupling to a PC using RS232, go to the following sections :

- Section 7 INSTALLATION
- Section 9 MESSAGE FORMATS
- Section 10 CONFIGURING

After you have successfully set up the WindSonic, we strongly advise that you then go back and read the rest of the manual to ensure that you get the best results from the WindSonic.

4 PRINCIPLE OF OPERATION

The WindSonic measures the times taken for an ultrasonic pulse of sound to travel from the North transducer to the South transducer, and compares it with the time for a pulse to travel from S to N transducer. Likewise times are compared between West and East, and E and W transducer.

If, for example, a North wind is blowing, then the time taken for the pulse to travel from N to S will be faster than from S to N, whereas the W to E, and E to W times will be the same. The wind speed and direction can then be calculated from the differences in the times of flight on each axis. This calculation is independent of factors such as temperature.

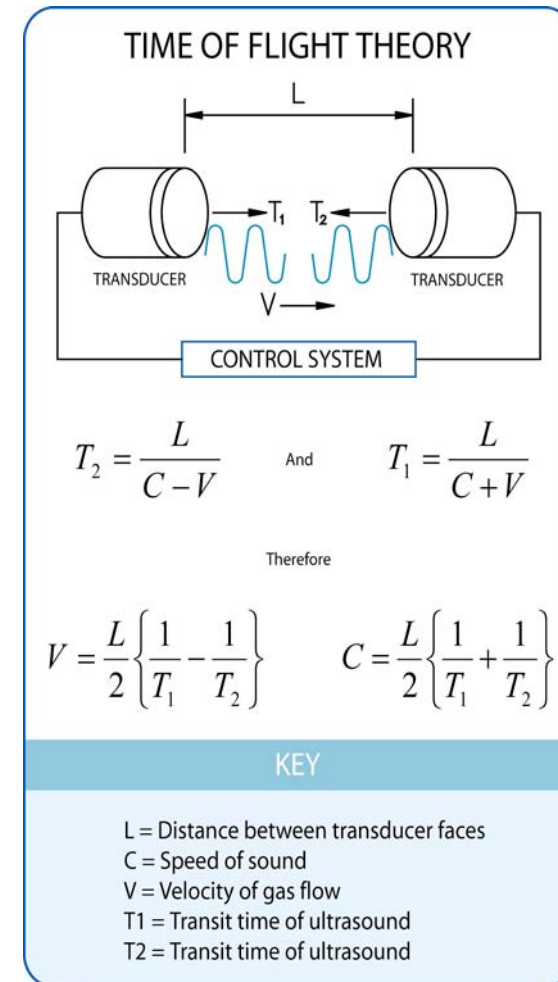

Figure 1 Time of Flight details

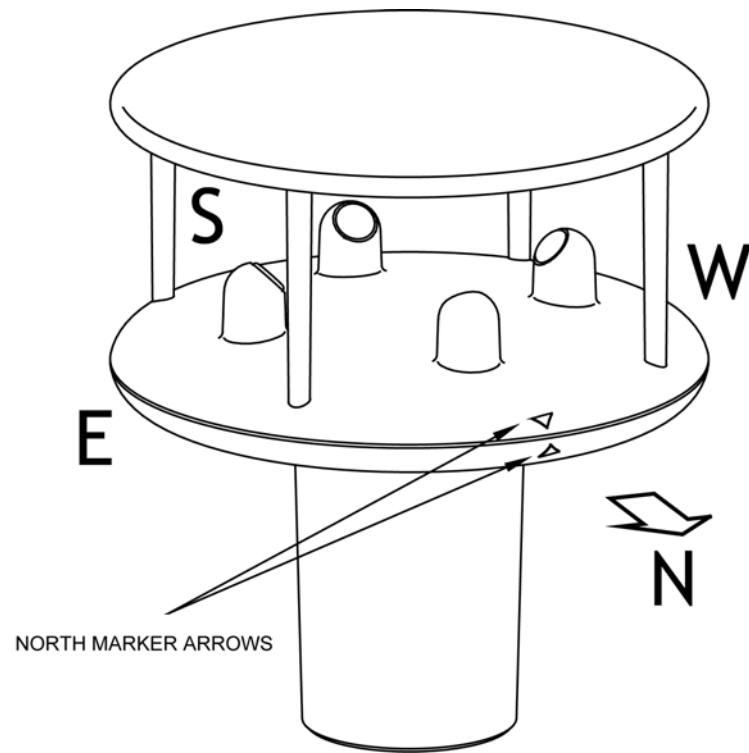

Figure 2 Compass Points

5 SPECIFICATION

Output		
Units of measure	Metres/second (m/s), Kilometres per hour (kph),	Knots, Miles per hour (mph), Feet per minute (fpm)
Output frequency	1, 2, or 4 outputs per second	
Parameters or	Digital	Analogue
	Polar - Speed and Direction UV - 2 axis, signed Speed	Polar - Speed and Direction Tunnel - U Speed and U Direction
Wind Speed		
Range	0 – 60 m/s	0 – 5m/s, 0 – 10m/s, 0 – 20m/s, 0 – 30m/s, 0 – 50m/s, 0 – 60m/s,
Accuracy	± 2% (at 12m/s)	± 2% (at 12m/s)
Resolution	0.01 m/s	0.01 m/s
Wind Direction		
Range	0 - 359°	0 - 359° or 0 - 539° (Wraparound mode)
Accuracy	± 3° (20m/s)	±3° (at 20m/s)
Resolution	1°	1°
Analogue output formats		
0-5V 4-20mA	± 1% of full scale N.B. Analogue output impedance = 1KΩ	
Digital output formats		
Gill	Continuous or Polled (output on request by host system) Polar (Speed and Direction) or UV (2 axis, signed Speed)	
Marine – NMEA Data Logger	NMEA 0183 version 3 SDI-12 V1.3	
Communication formats		
WindSonic Option 1	RS232	
WindSonic Option 2	RS232, RS422, RS485	
WindSonic Option 3	RS232, RS422, RS485, and Analogue (0 – 5V or 4 – 20mA)	
WindSonic Option 4	SDI-12	
	Note: WindSonic Option 4 is not compatible with WindCom	
Anemometer status	Status OK and Error codes included as part of standard output message	
Environmental		
Moisture protection	IP65	
Temperature	Operating -35°C to +70°C Storage -40°C to +80°C	
Humidity	Operating <5% to 100%	
EMC	EN 61000-6 - 3 (Emissions) EN 61000-6 - 2 (Immunity)	
Standards	Manufactured within ISO9001: 2000 quality system	

Power requirement	9 – 30 V DC. Current drain depends on variant i.e. RS232 approximately 14mA rising to 44mA for Analogue variant.
Mechanical	
Size / weight	142mm diameter x 160mm 0.5kg
Mounting	Pipe mounting 1.75 inches (44.45mm) diameter
Material	External - Acrylate Styrene Acrylonitrile, Polycarbonate blend.

6 PRE-INSTALLATION

6.1 Equipment supplied

Item	Quantity
WindSonic	1
Connector assembly comprising	
9 Way connector	1
Contacts	9
Sealing Gland	1
Washer	1
Washer shake proof	4
Screws – M5 stainless steel	4
User Manual	1

WindCom software is available free of charge from the Gill website – www.gill.co.uk

NOTE: WindSonic Option 1 – RS 232 output only
 WindSonic Option 2 – RS 232, 422 & 485 output
 WindSonic Option 3 – RS 232, 422, 485 & analogue output
 WindSonic Option 4 – SDI-12

Optional extras:

Item	Part No
Cable 4 Pair (Option 3 & 4 WindSonic)	026-03156
Cable 3 Pair (Option 1 & 2 WindSonic)	026-02660
WindSonic connector (1 supplied as standard see above)	1405-PK-050
WindSonic Support Tube	1405-30-056

6.2 Packaging

Whilst the WindSonic is being moved to its installation site, the unit should be kept in its inner packaging. All the packaging should be retained for use if the unit has to be returned at any time, or if a self test is performed.

6.3 Installation requirements

Host system - One of the following:

- PC fitted with a suitable interface to match the chosen communication format (RS232, RS422, or RS485), compatible with the WindSonic option selected, and a suitable Terminal Emulation software package. (For example Hyperterminal for Windows™ 9x, Windows™ 2000 and XP or Terminal for Windows™ 3.n will normally be available on your PC.) WindCom is available from the Gill website.
- Gill WindDisplay (WindSonic option 2 or 3 only)
- Other equipment with input/output compatibility to the WindSonic Option selected.

For example, Chart recorder or Data logger, using the WindSonic Analogue output or SDI-12 output.

Cable - To connect between the WindSonic and the host system

See Section 7.3 Cable type for cable specification.

- There are restrictions on the maximum cable lengths for correct operation.
- The cable should be routed up the inside of the mounting tube.

Mounting tube

- Standard tube 1.75 inches (44.45mm) Outside Diameter x 3mm wall thickness
See Figure 3 in section 7.4 Alignment & Mounting Details
- For non-hostile environments, Aluminium tube can be used.
- For hostile environments, you should select a material suitable for the intended environment. For example, stainless steel 316 for marine use.

6.4 Cable Assembly

Open the pack of parts provided with the WindSonic or as 1405-PK-050

Strip the cable and solder the contact pins to the cores (please note that the connector supplies the correct strain relief for cables with an outside diameter of 6-12mm).

Put the parts on the cable in the order as shown below.



Whilst squeezing the red retainer in the direction of ARROWS A, pull in the direction of ARROW B.



Your connector should now resemble the connector in the picture below.



Insert each contact pin until you feel a slight click. If you have inserted the contact into the incorrect hole it can be removed at this point by simply pulling it out. Please note there will be some resistance.



Rear View of Connector

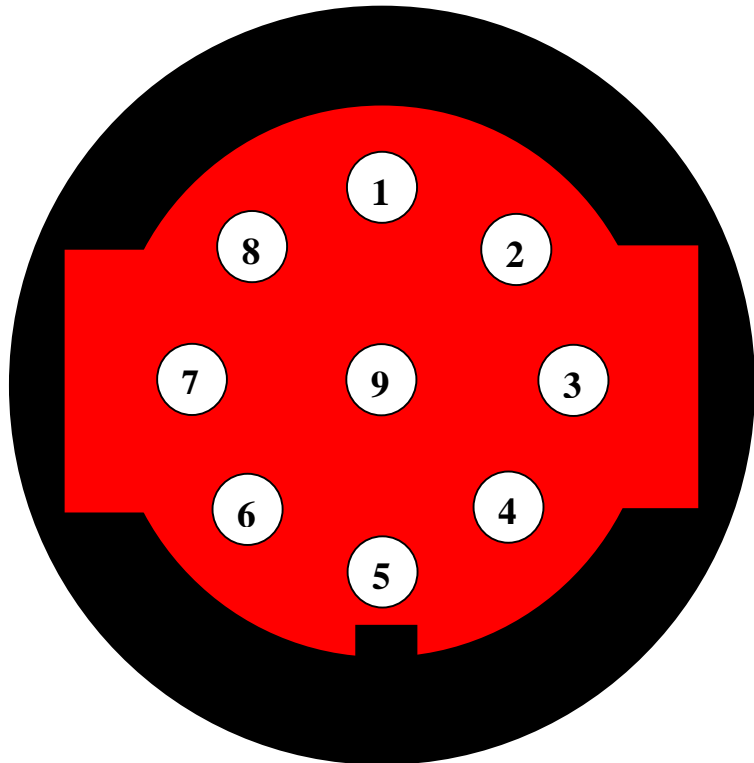

Continue to insert all of the contacts you require. Once all of the contacts are inserted push the red retainer into place. NB. The retainer can only be pushed back into place if the contacts are fully engaged.



Fit the connector to the WindSonic so that you can finish assembling the connector.



Screw the backshell onto the connector until it is fully in place. Please note that the final rotations can be slightly stiff.



Now screw the next part of the connector into place.



Now screw the cable-clamping nut into place.



The connector can now be removed from the WindSonic.

NOTE: To disassemble the connector, reverse this procedure.

6.5 WindCom

WindCom is available for the customer to download, free of charge, from the Gill Instruments Ltd website www.gill.co.uk.

WindCom features include:

- Data Display
- Data Logging
- Wind Alarms

NOTE: WindCom is not compatible with WindSonic Option 4 – SDI-12.

7 INSTALLATION

Do NOT remove the black “rubber” transducer caps. Warranty is void if the coloured security seal is damaged or removed.

7.1 Installation Guidelines

The WindSonic has been designed to meet and exceed the stringent standards listed in its specification. Operating in diverse environments all over the world, WindSonic requires no calibration and adjustment whatsoever.

As with any sophisticated electronics, good engineering practice should be followed to ensure correct operation.

- Always check the installation to ensure the WindSonic is not affected by other equipment operating locally, which may not conform to current standards, e.g. radio/radar transmitters, boat engines, generators etc.

Guidelines –

- Avoid mounting in the plane of any radar scanner – a vertical separation of at least 2m should be achieved.
- Radio transmitting antennas, the following minimum separations (all round) are suggested
 - VHF IMM – 1m
 - MF/HF – 5m
 - Satcom – 5m (avoid likely lines of sight)
- Use cables recommended by Gill. If cables are cut and re-connected incorrectly (perhaps in a junction box) then EMC performance may be compromised if cable screen integrity is not maintained.
- Earth loops should not be created – wire the system in accordance with the installation guidelines.
- Ensure the power supply operates to the WindSonic specification at all times.

Avoid turbulence caused by surrounding structures that will affect the accuracy of the WindSonic such as trees, masts and buildings. The WMO make the following recommendations:

- The standard exposure of wind instruments over level open terrain is 10m above the ground. Open terrain is defined as an area where the distance between the sensor and any obstruction is at least 10 times the height of the obstruction.

7.2 Bench system test

Note : Prior to physically mounting the WindSonic in its final location, we strongly recommend that a bench system test is carried out to confirm the system is configured correctly, is fully functional and electrically compatible with the selected host system and cabling (preferably utilising the final cable length). The required data format, units, output rate, and other options should also all be set up at this stage.

7.3 Electrical

Cable

Cable type

A RS422 compatible cable should be used, with the number of twisted pairs matching the application.

Generic description – Twisted pairs with drain wire, screened with aluminised tape, with an overall PVC sheath. Wire size 7/0.2mm (24 AWG)

The table shows some suitable manufacturers' references; other manufacturers' equivalents can be used.

Application	No. of pairs	Gill ref.	Belden ref.	Batt electronics ref.
WindDisplay	2	-	9729	-
RS 232	3	026-02660	9730	91030
RS 422/485	4	026-03156	9728	91199
SDI-12	2	-	9729	-

Cable length

The maximum cable length is dependent on the chosen communication format (RS232, RS422 or RS485), the baud rate, and, to a lesser extent, on the cable type and the local electrical 'noise' level.

The table shows the typical maximum lengths at the given baud rates, using the recommended cable. If any problems of data corruption etc are experienced, then a slower baud rate should be used. Alternatively, a thicker or higher specification cable can be tried.

WindSonic Option	Communication format	Baud rate	Max. cable length
Option 1	RS232	9600	6.5 m (20 ft)
Option 2	RS422/485	9600	1 km (3200 ft)
Option 3	Analogue – Voltage o/p	N/A	6.5 m (20 ft)
	Analogue – Current o/p	N/A	Resistance dependent (max 300 Ω)
Option 4	SDI-12	1200	90m (300ft)

Power supply

The WindSonic requires a DC supply of between 9 – 30 V DC. Current drain depends on variant i.e. RS232 approximately 14mA rising to 44mA for Analogue variant.

Note that the relative polarity of the connection of the DC supply to the WindSonic can be reversed. This is used for options 2 & 3, when the unit is configured in AUTO mode, to select the communication format.

See Section 10 Configuring

Configuring Hyperterminal

Note – Other terminal emulators are configured in a very similar way.

1. Decide on an available Com port that you want to use (Usually Com1).
2. Run Hypertm.exe (Typically accessed via Start → Programs → Accessories → Hyperterminal)
3. Create a New Connection (File → New Connection)
4. Enter a Name (eg WindSonic 1).
5. Change 'Connect Using' to 'Direct to Com 1' (or other Com port as required)
6. Adjust the Port settings to match WindSonic settings. WindSonic default settings are :

Bits per second 9600 **Data bits** 8 **Parity** None
Stop bits 1 **Flow Control** (Handshaking) None

Example of message format:

□ Q, 229, 002.74, M, 00, □ 06

See Section 10 Configuring if you need to change WindSonic settings.

Auto Mode

WindSonic (options 1, 2 and 3) are factory configured in Auto Mode (E1). This facility enables the customer to select RS232 or RS422/RS485 output when available by changing the wiring on the mating connector, see the following sections for further details.

WindSonic option 4 SDI-12 is factory configured in SDI-12 mode, see Section 11 SDI-12 Commands for details.

Connecting to a PC using RS232 (Options 1, 2 or 3)

Notes

1. Some PCs have a Serial RS232 interface and a suitable terminal emulation package already installed, which can easily be utilised with the WindSonic. (Hyperterminal for Windows™ 9x, Windows™ 2000 and XP or Terminal for Windows™ 3.n)
2. The cable length for reliable operation is limited to 6.5m (20ft).
(See Section 7.3 Cable length.)
3. For longer cable runs, we recommend using the WindSonic configured with RS422 output, and a RS422/232 converter at the PC. See *Connecting to a PC using RS422*.

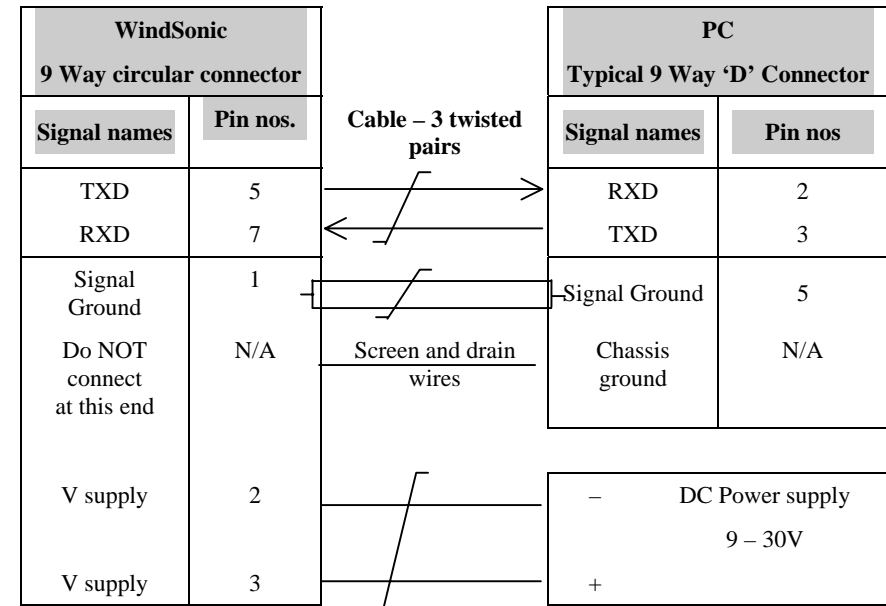

NOTE: Options 2 and 3 only reverse the polarity of the DC power supply to select RS422 output.

Connecting to a Gill WindDisplay

For further details see Section 8 USING WITH THE GILL WINDDISPLAY, and the WindDisplay User Manual for the method of operation.

Notes

1. WindSonic Option 2 or 3 must be used.
2. Use the WindSonic in the factory default mode – i.e. do not reconfigure.
3. The WindDisplay can provide power to the WindSonic

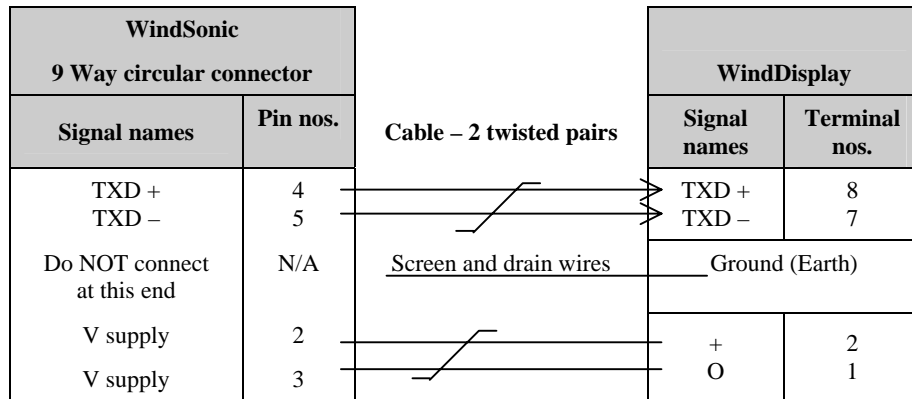

Default Settings

The WindSonic is factory configured with the following default settings:

M2, U1, O1, L1, P1, B3, F1, H1, NQ, E3

See Section 10 Configuring for further details

Connecting to a PC using RS422 (Option 2 or 3)

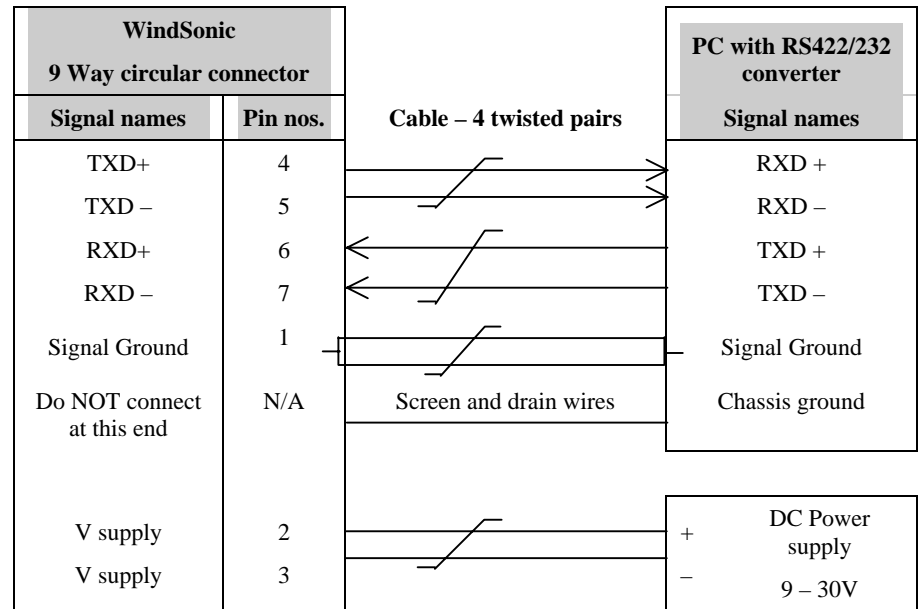

Configure the terminal emulator as previously described.

See Section 10 Configuring if you need to change WindSonic settings.

Networking using RS485 (Option 2 or 3)

Notes

- Up to 10 WindSonic units can be “daisy chained”.
- WindSonic units must be set in Polled mode, with each device given a unique node address.
See Section 9.1 WindSonic node address.
- Customers may poll using terminal software (NOT supplied).

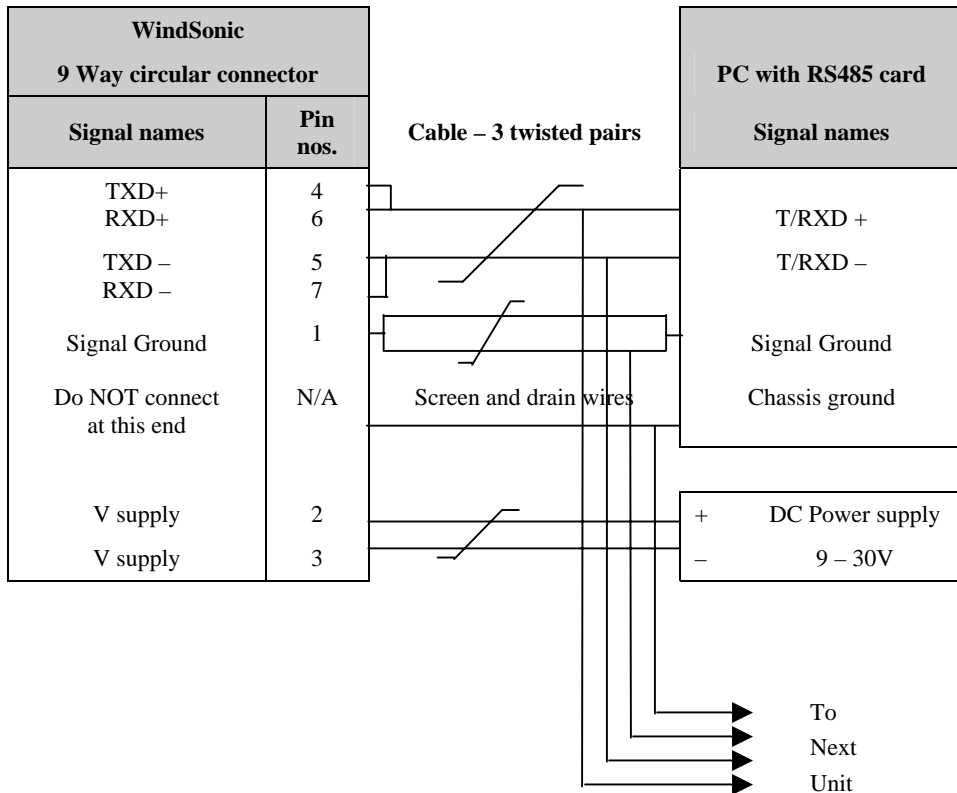

NOTE: Power needs to be supplied to each unit in the network
 NOTE: WINDCOM will not work in polled mode

Using the Analogue Output (Option 3)

Notes

- If the Current output is used, the total output load **MUST** be below 300 ohms, including the cable resistance.
- The current output loads must be returned to Signal Ground.
- Reconfiguration of the analogue output requires a digital connection (*See sections 9 & 10*)
- In addition, the digital output can be connected if required using RS232, 422 or 485, as shown in the previous sections.

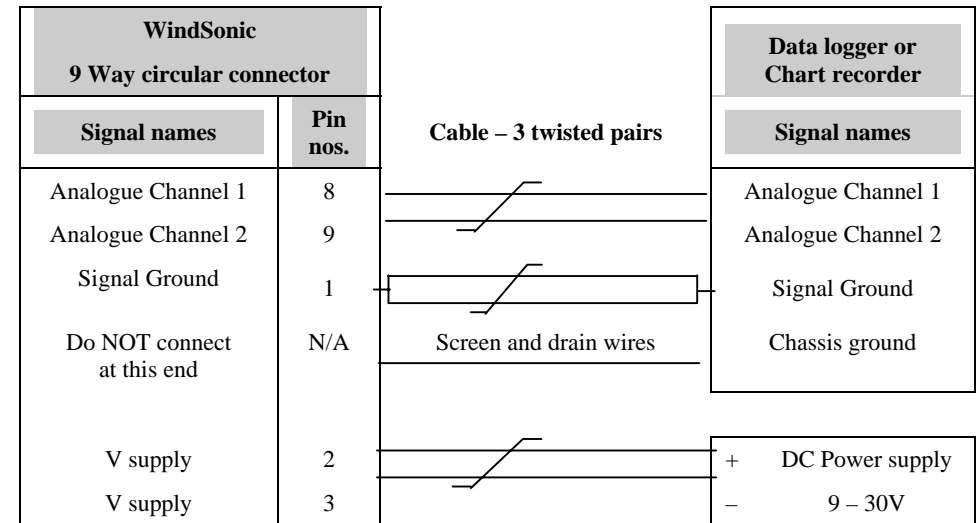

Note: Power supply connections above provide for analogue and RS422 outputs.
 Reverse wires on pins 2 and 3 for analogue and RS232 output.

Connecting to an SDI-12 Interface (Option 4)

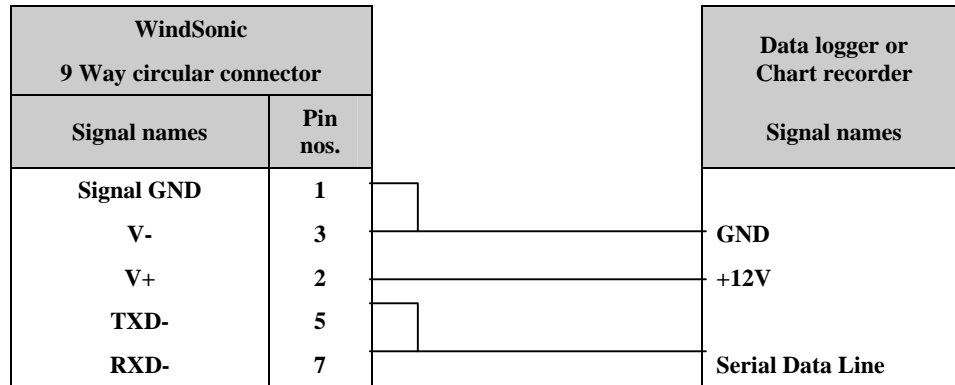

7.4 Mechanical

Before installing, see note at Section 7.2 Bench system test.

Orientation

Normally the WindSonic is mounted on a vertical tube, ensuring a horizontal Measuring Plane.

See Figure 3 Alignment & Mounting details

For indoor use the unit may be mounted with the Measurement Plane set to any required orientation.

Alignment

The WindSonic should be aligned to point to North, or any other reference direction –for example, the bow of a boat.

There are two arrows, a coloured rectangle, and an alignment notch to aid alignment.

See Figure 3 Alignment & Mounting Details

Note : It is usually simpler to work first with a compass at ground level and identify a suitable landmark and its bearing.

Mounting

The support tube requires three 3 equally spaced holes, tapped M5, 7.5mm from the top of the tube. Pass the cable (fitted with the 9 way Clipper plug) through the tube.

Note: the customer must fit appropriate strain relief to the cable.

Connect the plug by twisting it whilst pushing it gently into the socket on the WindSonic. When it locates, twist the outer sleeve clockwise to connect and lock the plug.

Fix the WindSonic to the tube using the 3 stainless steel screws provided. (Maximum mounting screw torque 4 Nm.)

It is the responsibility of the customer to ensure that the WindSonic is mounted in a position clear of any structure which may obstruct the airflow or induce turbulence.

Do NOT mount the WindSonic in close proximity of high powered radar or radio transmitters. A site survey may be required if there is any doubt about the strength of external electrical noise.

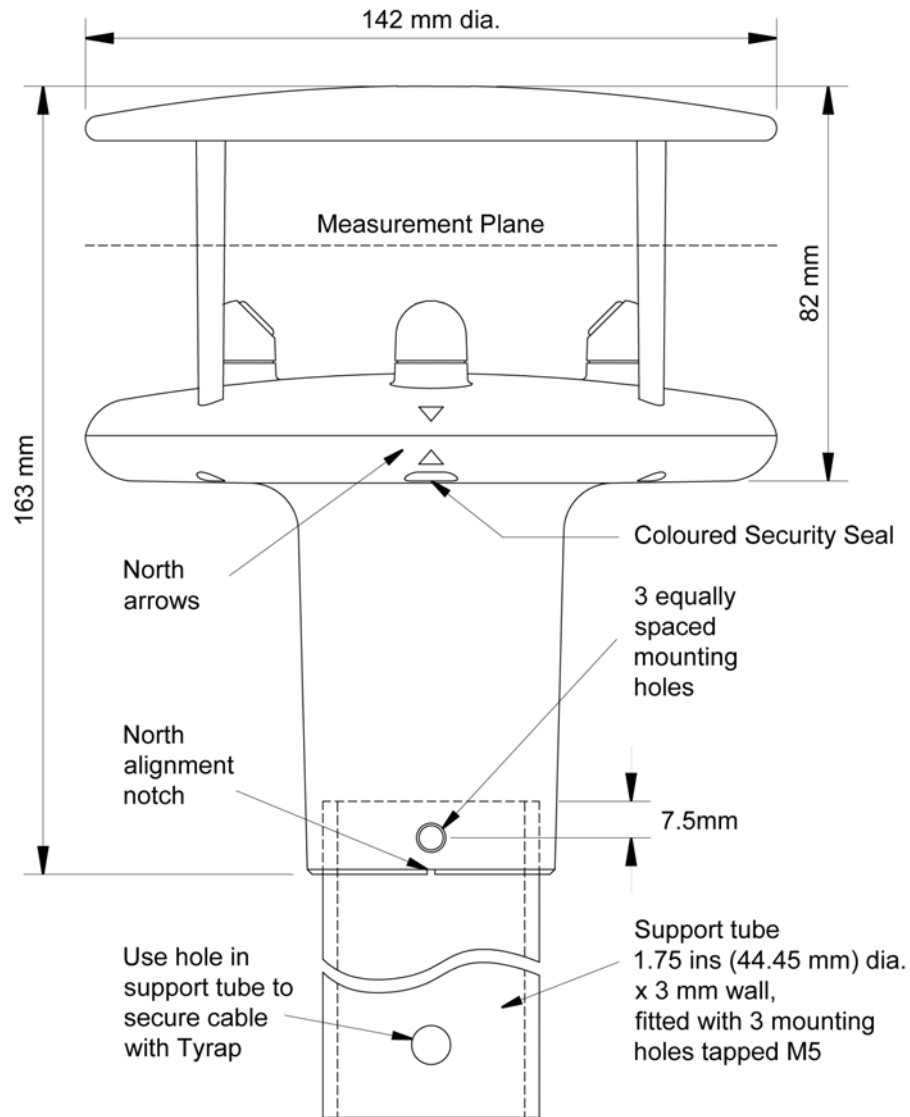

Figure 3 Alignment & Mounting details

8 USING WITH THE GILL WindDisplay

The WindSonic is designed to link directly to the Gill WindDisplay unit to provide a complete wind speed and direction system.

After coupling to a WindDisplay, the Wind Speed units and the Averaging period can be selected using the WindDisplay controls. See the *WindDisplay User Manual*.

Important :

- WindSonic Option 2 or 3 must be used, connected as shown in Section 7.3 Connecting to a Gill WindDisplay.
- The WindSonic must be used as supplied, set to the factory default settings. It must **NOT** be reconfigured.
- Note that although the WindDisplay can display wind speed in various units, these are calculated within the WindDisplay. The data coming to the WindDisplay must be in metres/sec (ie the factory default output setting).

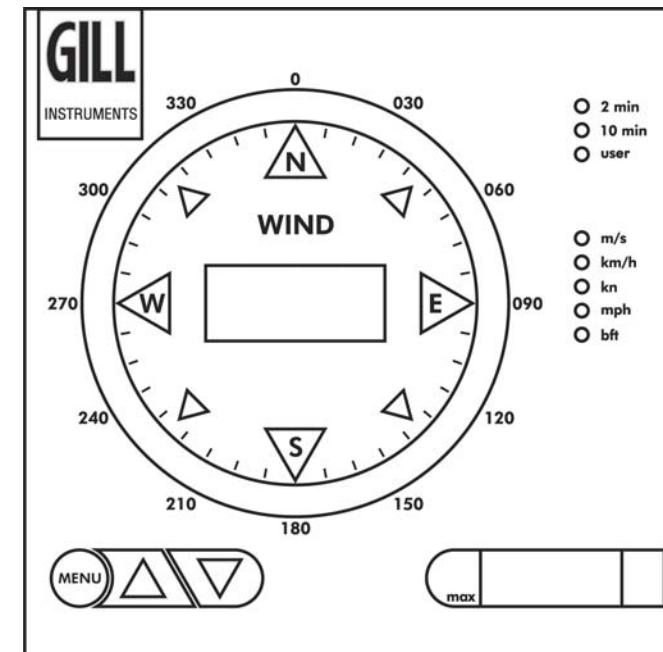

Figure 4 WindDisplay

9 MESSAGE FORMATS

On applying power to the WindSonic, it will provide wind measurements in one of the following formats:

- Gill – Polar, Continuous (**default format**)
- Gill - UV, Continuous
- Gill – Polled (Polar or UV)
- NMEA
- SDI-12 (Polled)

Each of these is described below.

Information on how to change the formats and settings follows in Section 10 CONFIGURING. If you purchased a WindSonic Option 4 SDI-12 refer to Section 11 SDI-12 COMMANDS. Sections 9 and 10 do NOT apply to WindSonic Option 4 SDI-12.

9.1 Gill format– Polar, Continuous (Default format)

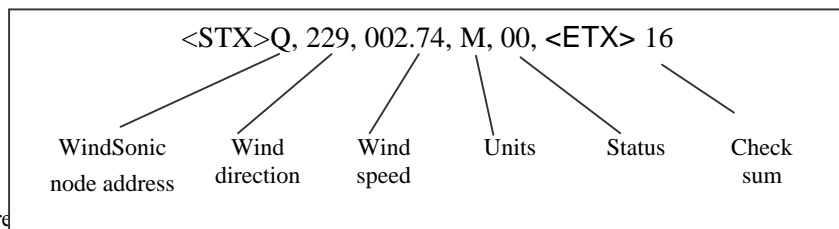

Where

<STX>	=	Start of string character (ASCII value 2)
WindSonic node address	=	Unit identifier
Wind direction	=	Wind Direction
Wind speed	=	Wind Speed
Units	=	Units of measure (knots, m/s etc)
Status	=	Anemometer status code (<i>see Section 12.5 for further details</i>)
<ETX>	=	End of string character (ASCII value 3)
Checksum	=	This is the EXCLUSIVE – OR of the bytes between (and not including) the <STX> and <ETX> characters.

WindSonic node address

The default setting is 'Q'. If there is more than one WindSonic in a network, the others must be renamed (R to Z), so that each WindSonic is uniquely identified.

Wind direction

Indicated in degrees, from 0 to 359°, with respect to the WindSonic North marker.

In fixed field mode and when the wind speed is below 0.05 metres/sec, the direction will not be calculated, but the last calculated direction above 0.05 m/s will be output.

Wind speed and units

Shows the Wind Speed in the Measurement Plane (*See Figure 3 Alignment & Mounting details*) in one of the following units:

Units	Identifier
Metres per second (default)	M
Knots	N
Miles per hour	P
Kilometres per hour	K
Feet per minute	F

Status

This indicates either

	Correct operation	Code 00
or	Error codes	<i>See Section 12.5 for explanation of codes.</i>

Checksum

This enables the host system to check that the data has been correctly received. This is the EXCLUSIVE – OR of the bytes between (and not including) the <STX> and <ETX> characters.

Output rate (not displayed)

The WindSonic samples continuously and delivers wind information at 1 (default setting), 2, or 4 outputs / second.

9.2 Gill format – UV, Continuous

In this mode, the output is given as signed (ie. positive or negative) speeds along the 'U' (= South – North) axis and the 'V' (= East – West) axis.

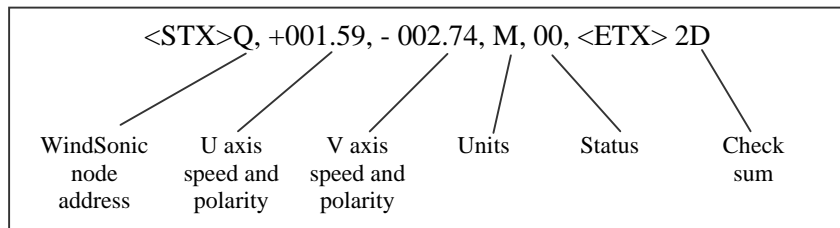

Where:

- <STX> = Start of string character (ASCII value 2)
- WindSonic node address = Unit identifier
- U axis = speed & polarity
- V axis = speed & polarity
- Units = Units of measure (knots, m/s etc)
- Status = Anemometer status code (see Section 12.5 for further details)
- <ETX> = End of string character (ASCII value 3)
- Checksum = This is the EXCLUSIVE – OR of the bytes between (and not including) the <STX> and <ETX> characters

The WindSonic unit identifier, Units, and Checksum are as described in Section 9.1 above. Figure 4 shows the polarity of U and V if the wind components along the U and V axis are blowing in the direction of the respective arrows.

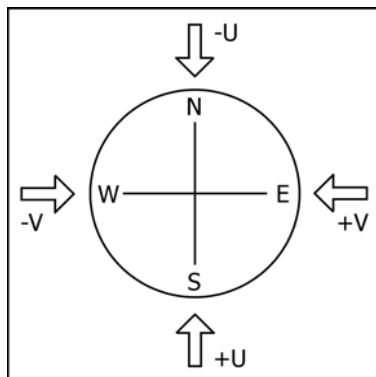

Figure 4 UV Polarity

9.3 Gill format – Polled (Polar or UV)

When in the Polled mode, an output is only generated when the host system sends a Poll signal to the WindSonic consisting of the WindSonic Unit Identifier – that is, the relevant letter Q – Z.

The output formats are otherwise as described in Sections 9.1 and 9.2.

The commands available in this mode are :

Description	Command	WindSonic response
WindSonic Unit Identifier	Q Z	Wind speed output generated
Enable Polled mode	?	(none)
Disable Polled mode	!	(none)
Request WindSonic Unit Identifier	&	Q Z (as configured)
Enter Configuration mode	*<N>	CONFIGURATION MODE

Where <N> is the unit identifier (See Section 10.13).

9.4 NMEA Format

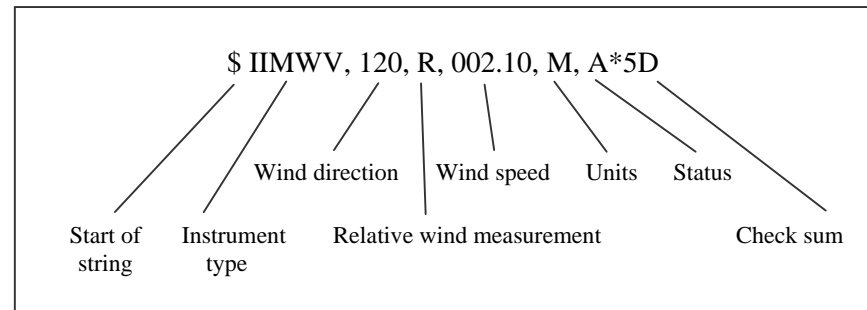

The **Wind Direction**, **Wind Speed**, and **Units** are as described in Section 9.1.

The **Instrument Type** – IIMWV - is a mnemonic for Integrated Instrument Mean Wind direction & Velocity.

The **Status** codes are :

- A Valid measurement
- V Invalid measurement

A typical WindSonic configuration suitable for NMEA (See Section 10):

M5, U1, O1, L1, P1, B2, F1, H1, NQ, E1

Consult specification NMEA 0183 version 3 (available on the web) for complete interface details.

9.5 Analogue outputs and options

Note : Analogue outputs are only available from WindSonic Option 3.

Voltage or Current output

The WindSonic (Option 3) can be configured for either Voltage (0 – 5 V) or Current (4 – 20 mA) outputs.

Important :

- When using the current outputs, the load resistance between the Analogue outputs (Pins 8 & 9) and Signal Ground must be ≤ 300 ohms, including cable resistance.
This is to ensure that the voltage levels on Pins 8 & 9 do not exceed 5V.
- The current outputs must be returned to Signal Ground (Pin 1).

Polar and Tunnel modes

If the WindSonic is configured in Gill Polar mode or NMEA mode, the analogue outputs will be in Polar mode.

If the WindSonic is configured in Gill UV mode, the analogue outputs will be in 'Tunnel' mode.

Analogue outputs	Polar mode	Tunnel mode
Channel 1 (Pin 8)	Wind speed	U speed
Channel 2 (Pin 9)	Wind direction	U direction

Polar mode direction wraparound

The Wind Direction in Polar mode can be configured for either Standard (0 - 359°) or Wraparound (0 - 539°) options. If the Standard mode is used with a chart recorder, large swings of the recorder pen will be experienced each time the wind direction passes between 0 and 359°. Using the Wraparound mode, when the wind first changes from 0° to 359°, there will be a step change on the output, but after this first time the output will change smoothly each time the wind passes through 360°. (Similarly, the first time the wind veers from 539° to 180°, there will be a step change, after which the output will change smoothly).

Wind direction (degrees)	Voltage output (V)		Current output (mA)	
	Standard	Wraparound	Standard	Wraparound
0	0	0	4.00	4.00
180	2.5	1.67	12.00	9.33
360	5.0	3.33	20.00	14.67
540	n/a	5.0	n/a	20.00

Low wind speeds in polar mode

Whilst the wind speed is below 0.05 metres/sec, the wind direction will not be calculated. In CSV mode, the Channel 2 output will switch between 0 and 5V (or 4 and 20mA) at the output rate selected.

In fixed field mode, the last valid direction will be output until a new value can be calculated.

Wind Speed scaling

The Wind Speed output can be configured such that full-scale output represents 5, 10, 20, 30, 50 or 60 metres/sec.

In all cases zero Wind Speed is represented by 0V or 4mA.

Tunnel mode

When configured in Tunnel mode, Channel 1 output represents the wind speed along the U axis (South – North) scaled as described above.

Channel 2 gives the direction of the wind along the U axis, where a –U vector (= wind from the N direction) is represented by 0V (or 4mA), and a +U vector is represented by 5V (or 20mA).

10 CONFIGURING

WindCom may be used to configure WindSonic, alternatively, the user may elect to use another terminal emulator package. This section describes the commands used to change User and Communications settings.

10.1 Entering Configuration mode

From Continuous mode

*
*

From Polled mode

* <N>
* <N>

where <N> is the Unit identifier

The WindSonic responds with a CONFIGURATION MODE message, stops reporting wind measurements, and waits for a command (as detailed below).

10.2 Returning to Measurement mode

Q ENTER

The WindSonic responds with wind measurements immediately when in Continuous mode, or on receipt of a Poll signal when in Polled mode.

10.3 Checking the configuration

We recommend that, as a standard procedure, you use this command prior to, and after, changing any settings. It shows the current settings for all the alterable settings.

*
D 3 ENTER

The WindSonic responds with the default settings shown below:

M2, U1, O1, L1, P1, B3, F1, H1, NQ, E1

We suggest you note down the settings, so that you can easily return to them.

Return to measurement mode

Q ENTER

All of these settings are explained in the following sections.

10.4 Changing a setting

To change a setting, refer to the sections below, and enter the command of the new setting required, followed by ENTER. If successful, the new setting will be sent as a message by the WindSonic.

For example, to change the message format to NMEA, enter M 5 ENTER

The WindSonic will reply M5. When the unit is returned to the Measurement mode, it will be in NMEA format.

Note : The factory-set (default) settings are shown in **bold** in the following sections.

10.5 Measurement settings

Item	Options	Command
Message format	Gill, UV, Continuous	M1
	Gill, Polar, Continuous	M2
	Gill, UV, Polled	M3
	Gill, Polar, Polled	M4
	NMEA	M5

10.6 Output Units

Item	Options	Command
Output units	Metres per second (M)	U1
	Knots (N)	U2
	Miles per hour (P)	U3
	Kilometres per hour (K)	U4
	Feet per minute (F)	U5

10.7 ASCII output format

Item	Options	Command
ASCII output format	Comma separated format (CSV)	O1
	Fixed field	O2

10.8 Message Terminator

Item	Options	Command
Message terminator	<CR> <LF>	L1
	<CR>	L2

10.9 Output Rate

Item	Options	Command
Output rate	1 per second	P1
	4 per second	P2
	2 per second	P3

10.10 Baud rate

Item	Options	Command
Baud rate	2400	B1
	4800	B2
	9600	B3
	19200	B4
	38400	B5

If a request is sent to change the Baud rate, before it changes it must be confirmed by entering **B** **ENTER** at the new Baud rate.

eg. If set to B3 (9600 baud), to change to B5 (38400 baud), enter **B** **5** **ENTER** , change host terminal to 38400 baud, and confirm by entering **B** **ENTER**.

NOTE: a random echo will be generated after the B5 confirmation

10.11 Data and parity options

Item	Options	Command
Data and parity options	8 bits, no parity	F1

10.12 Power-up Message

Item	Options	Command
Power –up message	ON	H1
	OFF	H2

If the power up message is On, then a message similar to that below is output, whenever the unit goes into Measurement mode (ie. when power is first applied to the unit, or unit returns to Measurement mode from Configuration mode).

```

WINDSONIC (Gill Instruments Ltd)
FIRMWARE: 2231 - 102
RS232 (CFG)   RS 232(Auto)
CHECKSUM ROM  9F5E  9F5E  *PASS*
CHECKSUM FAC  04F4  04F4  *PASS*
CHECKSUM ENG  0824  0824  *PASS*
CHECKSUM CAL  DFBF  DFBF  *PASS*

```

If any of these checksums fail, the word PASS will be replaced by FAIL and the unit will use its default settings. If the checksum repeatedly fails after power on – contact your supplier.

NOTE: The exact message above will vary.

10.13 Node Address

Item	Options	Command
Node Address	Q.....Z	N<Q>

10.14 Communications Protocol

Item	Options	Command
Communications protocol	AUTO	E1
	RS422 / RS485	E2
	RS232	E3

Changes must be confirmed by entering **E** **ENTER**.

e.g. If set to E1 (AUTO), to change to E2 (RS422/RS485), enter **E** **2** **ENTER**, change over the communications wiring (unit must remain powered up) and then confirm in terminal package by entering **E** **ENTER**.

10.15 Analogue settings

The following commands are only valid for the WindSonic Option 3 :

Item	Options	Command
Voltage or Current output	0 - 5 Volt	T1
	4 - 20 mA	T2
Analogue range	0 - 10 metres per second	S1
	0 - 20 metres per second	S2
	0 - 30 metres per second	S3
	0 - 50 metres per second	S5
	0 - 60 metres per second	S6
	0 - 5 metres per second	S7
	Analogue output disabled	S9
Analogue Wraparound	Wrap around 0 - 539°	C1
	Normal 0 - 359°	C2

Where:

Analogue range	=	Customer selected range
Analogue wraparound	=	Chart recorder facility
Voltage or current output	=	Output type

Polar mode direction calculation

The system will not calculate a wind direction when the measured velocity falls below 0.05m/s. When configured for fixed field mode the direction output will hold the last setting until a new direction can be calculated. If the unit is in CSV mode, the output will switch between 0 and 5V (or 4 to 20mA) at the output rate selected.

Magnitude scaling

The magnitude output can be scaled such that the full scale output represents either 5, 10, 20, 30, 50 or 60ms⁻¹.

Error conditions

If a valid wind measurement cannot be calculated (for example all paths blocked), the outputs 1 and 2 will switch between 0 and 5V (or 4 to 20mA) at the output rate selected.

Disabled outputs

If the analogue outputs are not required, they can be disabled (Command S9).

10.16 Configuration / Diagnostic Information

Each of these commands causes a response from the WindSonic.

Item	Command	Response
Type and serial No.	D1	TYPE: Y SERIAL NO.: 012345
Software version	D2	FIRMWARE: 2231-102
Unit configuration	D3	M2,U1,O1,L1,P1,B3,F1,H1,NA,E3,
Analogue ID (if present)	D4	EXP MOD ID: 0 D4 = 0 (No Analogue outputs) D4 = 1 (Analogue outputs enabled)
Self test	D6	<i>See Section 13.2 Self-Test (Still Air)</i>

11 SDI-12 COMMANDS

WindSonic Option 4 complies with SDI-12 Interface Standard V1.3

We advise that you download the full SDI-12 specification from www.sdi-12.org

All other commands not defined below respond with a 'zero data values ready' response.

All units of measurement are in metres per second. This cannot be re-scaled.

Name	Command	Gill Output
Continuous Measurement (Polar)	aR0!	a<dir><mag><status><CR><LF>
Continuous Measurement (UV)	aR1!	a<U><V><status><CR><LF>
Continuous Measurement with CRC (Polar)	aRC0!	a<dir><mag><status><CRC><CR><LF>
Continuous Measurement with CRC (UV)	aRC1!	a<U><V><status><CRC><CR><LF>
Start Measurement (Polar)	aM!	a0003
Send Data	aD0!	a<dir><mag><status><CR><LF>
Start Measurement (UV)	aM1!	a0003
Send Data	aD0!	a<U><V><status><CR><LF>
Start Measurement with CRC (Polar)	aMC!	a0003
Send Data	aD0!	a<dir><mag><status><CRC><CR><LF>
Start Measurement with CRC (UV)	aMC1!	a0003
Send Data	aD0!	a<U><V><status><CRC><CR><LF>
Acknowledge Active	a!	a<CR><LF>
Send Identification	aI!	a13GillInst 1405 SDI v101 <sn><CR><LF>
Change Address	aAb!	b<CR><LF>
Address Query	?!	a<CR><LF>
Measurement on demand	aXLPM!	0LP<CR><LF>
Continuous Reading	aXHPM!	0HP<CR><LF>
Default operating mode aXHPM!		

Gill Output Message Format

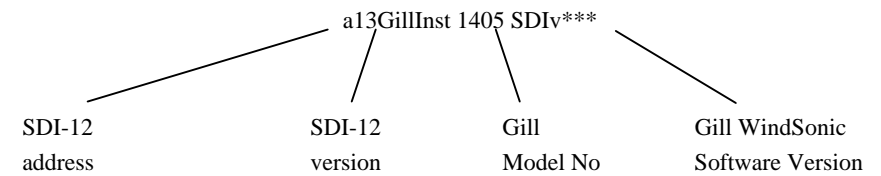

*** Software Version may change

12 MAINTENANCE & FAULT-FINDING

12.1 Cleaning

If there is any build up of deposit on the unit, it should be gently cleaned with a cloth moistened with soft detergent. Solvents should not be used, and care should be taken to avoid scratching any surfaces. The unit must be allowed to defrost naturally after being exposed to snow or icy conditions, do NOT attempt to remove ice or snow with a tool.

Do NOT remove black “rubber” transducer caps.

12.2 Servicing

There are no moving parts or user-serviceable parts requiring routine maintenance.

Opening the unit or breaking the security seal will void the warranty and the calibration.

In the event of failure, prior to returning the unit to your authorised Gill distributor, it is recommended that :

1. All cables and connectors are checked for continuity, bad contacts, corrosion etc.
2. A bench test is carried out as described in Section 13.1.
3. You contact your supplier for advice

12.3 Fault Finding

Symptom	Solution
No output	<p>Check DC power to WindSonic, cable and connections.</p> <p>Check comms settings of WindSonic (<i>as detailed in Section 10</i>) and host system match, including correct Com port</p> <p>Check unit is in Continuous mode</p> <p>Check that in-line communication devices are wired correctly.</p> <p>NOTE: It is usual for Anemometer TX + to be connected to converter device RX +</p>
Corrupted output	<p>Check comms settings of WindSonic and host system match.</p> <p>Try a slower baud rate.</p> <p>Check cable lengths and type of cable.</p>
One way communication	<p>Check WindSonic and host system are both set to the same protocol RS232, RS422, or RS485.</p> <p>Check wiring is in accordance with the manual.</p>
Failed / Incorrect WindSonic output, data invalid flag	<p>Check that transducer path is not blocked</p>

12.4 Returning Unit

If the unit has to be returned, it should be carefully packed in the original packaging and returned to your authorised Gill distributor, with a full description of the fault condition.

12.5 Status

The Status code is sent as part of each wind measurement message.

Code	Status	Condition
00	OK	Sufficient samples in average period
01	Axis 1 failed	Insufficient samples in average period on U axis
02	Axis 2 failed	Insufficient samples in average period on V axis
04	Axis 1 and 2 failed	Insufficient samples in average period on both axes
08	NVM error	NVM checksum failed
09	ROM error	ROM checksum failed
10	System gain at maximum	Wind velocity reported could be in error
A	-	NMEA data valid
V	-	NMEA data invalid

13 TESTS

13.1 Bench test

1. Couple the WindSonic to the host system and power supply, using a known working test cable.
2. Check that the unit is correctly configured by going into Configuration mode and using **D3** See Section 10.3 Checking the configuration.
3. Check for normal output data, and that the Status Code is OK – 00 (or A for NMEA format).
4. If the status code is other than 00, refer to Section 12.5 Status (error) codes.
5. Use an office fan or similar to check that the unit is sensing wind, turning the unit to simulate changing wind direction and to check that both axes are functioning.
6. Note that this a quick functional test. There are no calibration adjustments; the unit is designed NOT to require re-calibration within its lifetime.

13.2 Self-Test (Still Air)

This test checks Alignment, Gain and Checksums.

Alignment tests : The unit performs a transducer geometry check and compares the result with its factory setting.

Gain tests : The unit performs a check of its operating gain against its factory setting.

Checksum tests : The unit performs a check of its program and data memory.

Important This test is a stringent laboratory test which will only be passed if carried out under still air conditions at room temperature (17-23°C). **NOTE:** Option 4 SDI-12 units must be in Gill mode for the self test to function (see Section 11) .

1. Use the original packing box (inner and outer) to enclose the unit. (The packaging is designed as a zero wind enclosure).
2. Go into Configuration Mode ***** **ENTER** .
3. Carry out the Self-test by entering **D 6 ENTER** .

A message similar to that shown below will be generated :

```
ALIGNMENT LIMITS:0D59,0CF5
ALIGNMENT U:0D15 *PASS*
ALIGNMENT V:0D16 *PASS*
GAIN 0:0001 *PASS*
GAIN 1:0001 *PASS*
GAIN 2:0001 *PASS*
GAIN 3:0001 *PASS*
CHECKSUM ROM:AB7D AB7D *PASS*
CHECKSUM FAC:04F4 04F4 *PASS*
CHECKSUM ENG:082A 082A *PASS*
CHECKSUM CAL:A9C1 A9C1 *PASS*
```

For each of the Alignment and Gain tests a Pass or Refer to Manual message is generated.

For each of the Checksum tests a Pass or Fail message is generated.

4. If any of the tests fail, contact your supplier.

If a “refer to manual” message appears please see Section 12.3 Fault Finding.

Note that it will only pass if the specified temperature and zero wind conditions are met.

Check that there are no visible obstructions or damage to the unit before contacting Gill or your authorised distributor for further advice.

13.3 Calibration

A Custom calibration is available from Gill Instruments. This must be specified at the time of order or the unit must be returned to Gill Instruments for retrospective calibration.

14 APPENDICES

14.1 Glossary & Abbreviations

Item	Meaning
CAL	Calibration
CR	Carriage Return
CSV	Comma Separated Variable
ENG	Engineering
FAC	Factory
KPH	Kilometres per Hour
LF	Line Feed
MPH	Miles per Hour
NMEA 0183 (version 3)	National Marine Electronics Association standard for interfacing marine electronic navigational devices
NVM	Non-Volatile Memory
PC	IBM compatible Personal Computer
ROM	Read Only Memory
RS232	Communications standard
RS422	Communications standard
RS485	Communications standard
RXD	Received Data
TXD	Transmitted Data
SDI-12	Serial – Data Interface standard for microprocessor based sensors
WMO	World Meteorological Organisation

14.2 Guarantee

For terms of guarantee contact your supplier.

Warranty is void if the coloured security seal is damaged or broken, or the transducer caps have been damaged.

14.3 Electrical Conformity



EC DECLARATION OF CONFORMITY ACCORDING TO COUNCIL DIRECTIVE 89/336/EEC

We, Gill Instruments Ltd., declare under our sole responsibility that the products :

WindSonic Ultrasonic Anemometer – Options 1, 2, 3 and 4

Manufactured by : Gill Instruments Ltd

to which this declaration relates, are in conformity with the protection requirements of Council Directive 89/336/EEC on the approximation of the laws relating to electromagnetic compatibility.

This Declaration of Conformity is based upon compliance of the product with the following harmonised standards:

Emissions EN61000 - 6 -3

Immunity EN61000 - 6 -2 *

* Excluding 150kHz to 250kHz Conducted Immunity

Signed by:

A handwritten signature in black ink that reads "A.C.R. Stickland".

A.C.R. Stickland – Director

Date of issue: 30/5/2003

Place of issue: Gill Instruments Ltd
Saltmarsh Park, 67 Gosport Street,
Lymington, SO41 9EG, UK

